

Demonstration of GMPLS-controlled Integrated IP/WDM Routing over a Grooming-capable ASON/GMPLS Network Test-bed

Jordi Perelló, Luis Velasco, Fernando Agraz, Salvatore Spadaro, Jaume Comellas and Gabriel Junyent

Advanced Broadband Communications Center (CCABA), Universitat Politècnica de Catalunya (UPC),
Jordi Girona 1-3, 08034 Barcelona (Spain). E-mail: perello@ac.upc.edu

Abstract This paper demonstrates the benefits of GMPLS-based integrated routing and grooming in a 16-Node ASON/GMPLS network test-bed. Experimental results highlight significant blocking probability and E/O port usage reduction against all-optical and opaque transport network alternatives.

Introduction

The current Internet traffic explosion has evidenced the necessity of next-generation transport network architectures that relieve electronic IP routers from the processing of all incoming data traffic. In this regard, all-optical networks (AONs) establish end-to-end light-paths optically bypassing highly overloaded intermediate IP routers.

These light-paths, however, are provisioned in AONs with a whole wavelength granularity (2.5, 10 or even 40 Gbps), which exhibits a poor bandwidth efficiency when supporting sub-wavelength flows. Aiming to bridge the gap between higher layer technologies (e.g., MPLS or SDH) and the DWDM-enabled optical layer, multi-layer networks have been additionally proposed. In order to achieve optimal bandwidth utilization, these networks follow a *peer* architectural model, where all layers are governed by a common control plane, and each node has knowledge about the state of all resources at each composing layer.

The enabling technology to this integrated control plane is Generalized Multi-Protocol Label Switching (GMPLS¹), which creates a Label Switched Path (LSP) hierarchy spanning different switching domains (Packet, TDM, Lambda and Fiber). Into operation, GMPLS provides multi-layer networks with the automation required to dynamically create and release connections, to route them efficiently, and to maintain all resources in the network.

Paving the way to a wide-scale commercial deployment of GMPLS-enabled multi-layer networks, this paper reports the implementation and experimental assessment of the GMPLS integrated routing functionalities in the CARISMA Test-bed, a grooming-capable ASON/GMPLS transport network. Essentially, the CARISMA Test-bed stands for an out-of-fiber multi-topology Signaling Communications Network (SCN), running over Wavelength Selective Switch (WSS) based Optical Cross Connect (OXC) emulators. As depicted in Fig. 1, a 16-Node transport network with average node degree equal to 2.88 has been configured in this work. In the test-bed, each Optical Connection Controller (OCC) implements the full GMPLS protocol set, that is, RSVP-TE for signaling, OSPF-TE for link state dissemination and LMP for resource discovery and maintenance.

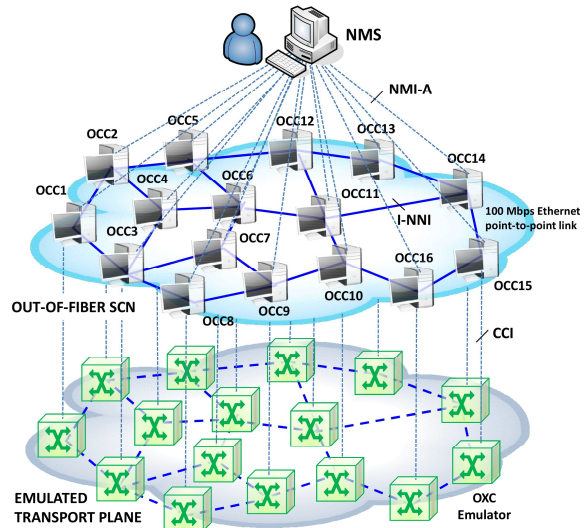

Fig. 1: The ASON/GMPLS CARISMA Test-bed

Implementation of GMPLS traffic grooming

In GMPLS-enabled transport networks, the traffic grooming functionality results in merging client LSPs into lower order LSPs (e.g., λ -LSPs). The key entity in this process is the Forwarding Adjacency (FA). When a lower order LSP is set up for supporting a client LSP request, OSPF-TE advertises it as a FA-LSP. As defined in IETF RFC 3630 and RFC 4203, several Type-Length Value (TLV) fields describe the attributes of the newly created FA-LSP, such as the multiplexing capability, maximum reservable and unreserved bandwidth, or the list of nodes the FA-LSP traverses (Explicit Route Object, ERO). This FA-LSP will then enter the path computation process along with all unallocated data links in the network.

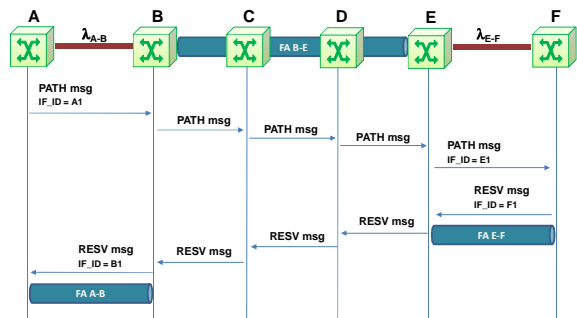

Fig. 2: Client LSP signaling process involving FA-LSPs

Fig. 2 depicts the signaling procedures between nodes A-F involving an existing FA-LSP between B-E. In this case, two new λ -LSPs (A-B, E-F) must be established to support the client LSP A-F, which will reuse part of the spare capacity in FA-LSP B-E.

In RFC 3477, the IETF proposes a new RSVP-TE object called LSP_TUNNEL_INTERFACE_ID to be used during the FA-LSP signaling process. This object contains the origin router ID and the FA-LSP ID sub-objects. Specifically, the FA-LSP ID is filled with the ID of the output interface supporting the λ -LSP being signaled. As soon as the RSVP-TE Path message reaches the λ -LSP tail-end OCC (e.g., the outgoing Path message from node A reaches node B in Fig. 2), this node selects a remote FA-LSP ID as well, which will be reported back to the head-end node in the RSVP-TE Resv message.

Once a λ -LSP is established, the head-end node advertises it as a FA-LSP. If the λ -LSP is bidirectional, it is also advertised by the tail-end node (i.e., head-end node on the reverse direction). As a result, each OCC receiving the advertisement can store it in their Traffic Engineering Databases (TEDs) for future route calculations. In case that not a new λ -LSP, but an existing FA-LSP is signaled, both ends advertise the new FA-LSP bandwidth attributes once the incoming client LSP request is allocated.

Experimental evaluation

The GMPLS integrated routing performance has been evaluated in the ASON/GMPLS CARISMA Test-bed, which implements all FA-LSP related functionalities. For the evaluation, the 16-Node scenario depicted in Fig. 1 with 8 bidirectional wavelengths/link has been assumed. There, uniformly distributed bidirectional client LSP requests demanding 1/4 of the total wavelength capacity arrive to the network following a Poisson process. In particular, λ -LSPs are routed in the network so that they accomplish the wavelength continuity constraint.

Three different network architectural solutions have been analyzed: *all-optical*, *generic FA* and *opaque*. The first solution stands for an AON, where an end-to-end light-path with the whole wavelength capacity is established per client LSP request. The second solution, *generic FA*, identifies the GMPLS-controlled traffic grooming exactly as explained in the previous section. Finally, the third solution contemplates an opaque transport network, where only single-hop λ -LSPs are allowed. Once established, these LSPs are advertised as FA-LSPs permitting their re-use. Fig. 3 shows the network Blocking Probability (PB) and E/O port usage results for each solution.

In the upper figure, PB is drastically reduced when implementing the FA-LSP functionality in the network. For instance, fixing a PB value around 0.5%, the offered load to the network in the *generic FA* and *opaque* solutions can be increased by 0.6 compared

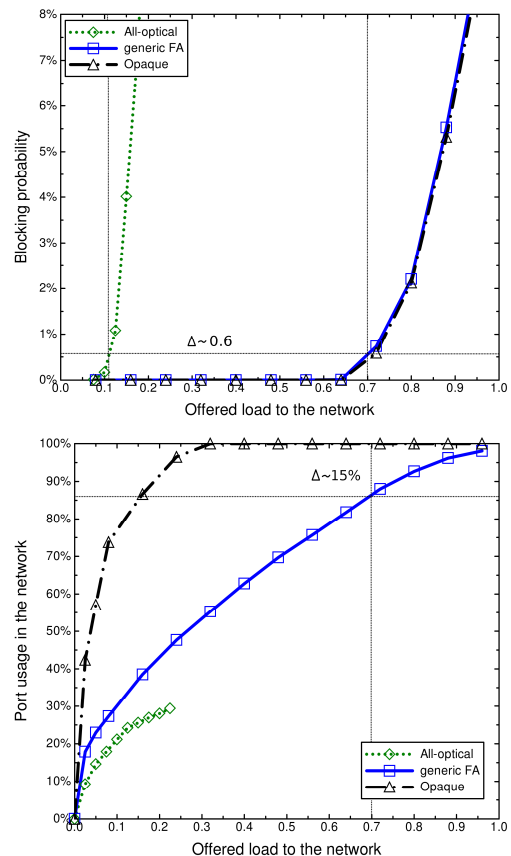

Fig. 3: Blocking probability (top); E/O port usage (bottom)

to the *all-optical* one. This validates the GMPLS grooming functionality, imposing it as a strong requirement in next-generation transport network.

The figure at the bottom quantifies the E/O port usage in the network, an indicator of the related network CAPEX. To this end, the Y axis has been normalized to the maximum number of E/O ports that could be equipped in the network (one per output wavelength at each node).

As seen, besides pleading for huge electronic routers, able to process all the incoming information at the nodes, the *opaque* solution rapidly requires a large number of E/O ports, since an optical bypass is not possible in the network. Conversely, although the *all-optical* solution leads to the lowest port usage, this is mandated by its poor bandwidth efficiency, which forces it to consume all available wavelength channels. Interestingly, the *generic FA* lies between both solutions. As seen before, it leads to similar PB than the *opaque* solution. Nonetheless, thanks to the optical bypass capability, it leads to a lower E/O port usage, thus reducing the total CAPEX. Note that for an offered load of 0.7, leading to the same PB around 0.5%, the E/O port usage is decreased by 15%.

Acknowledgements

This work is funded by the Spanish Science Ministry through the project ENGINE (TEC2008-02634).

References

1 E. Mannie, IETF RFC 3945, October 2004.