

Global Concurrent Optimization: Advantages and Opportunities in Flexgrid-Based Networks

A. Castro*, L. Velasco, J. Comellas, G. Junyent

Universitat Politècnica de Catalunya (UPC), Barcelona, Spain

*e-mail: acastro@ac.upc.edu

ABSTRACT

In future flexgrid core networks the amount of lightpaths might increase significantly as a consequence of the finer granularity in the use of the optical spectrum. Different spectrum bandwidth can be allocated to each lightpath as a function of, among others, the bitrate amount to be conveyed and the modulation format used. As result, spectrum fragmentation might appear leading to non-optimal resource utilization. In addition, a failure in a fibre link could trigger hundreds, or even thousands, of path computations requests to a centralized Path Computation Element (PCE). Latter examples can benefit from using the recently standardized Global Concurrent Optimization (GCO), which enhances PCE's computation capabilities. In this paper we present two opportunities to take advantage of the PCE+GCO architecture: spectrum defragmentation and restoration.

Keywords: Flexgrid Optical Networks, Spectrum defragmentation, Dynamic Bulk Restoration.

1. INTRODUCTION

Recent advances in optical modulation formats, filtering, and digital signal processing, among others, are enabling flexgrid components to be produced; finer granularity and flexibility in the use of the optical spectrum compared to that of the fixed grid can be achieved [1]. For flexgrid-based optical core networks to be deployed, bandwidth-variable optical cross-connects (BV-OXC), equipped with bandwidth-variable wavelength selective switches, and multi-flow transponders (MF-TP) need to be commercially available [2]-[4]. Installed in IP/MPLS routers and connected to a BV-OXC, MF-TPs add extra flexibility allowing several optical connections (lightpaths) to be terminated in each of them.

As a consequence of the introduction of flexgrid networks, grooming could be partially done at the optical layer reducing the amount of IP/MPLS routers that need to be installed in a network [5]. However, those routers would be still needed to fill the gap between the bitrate of IP/MPLS client flows coming from access and metro networks (e.g. 1 Gb/s) and the capacity of one slot lightpath (in the order of 10 Gb/s when 6.25 GHz slot width and the quadrature phase shift keying, QPSK, modulation format are used).

To operate those multilayer IP/MPLS-over-flexgrid networks, a distributed control plane with a centralized Path Computation Element (PCE) [6] can be used. The standardized PCE computes routes in response to path computation requests. It takes advantage of a traffic engineering database (TED) that is updated after network resources are effectively used or released. Recently, efforts to introduce enhanced computation capabilities in the PCE have concluded with the standardization of Global Concurrent Optimization (GCO) [7]. GCO aims at serving path requests attaining the optimal solution for the whole network.

In this paper we summarize the main conclusions from our previous work in [8] and [9] where we proposed taking advantage of using a PCE+GCO architecture for spectrum defragmentation and single failure restoration.

2. SPECTRUM REALLOCATION PROBLEM

As a consequence of connections dynamicity and of the various amounts of contiguous frequency slots required for the connections, the spectrum of the optical network is highly fragmented increasing thus the blocking probability. We propose the Spectrum REaLLOcation (SPRE (LLO)→(SSO)) [8] that reallocates already established paths in the spectrum to make enough room for a new incoming connection request.

Our approach for spectrum defragmentation follows the path-triggered spectrum defragmentation in flexgrid optical networks whenever not enough resources have been found for a connection request. Every link in the routes from a set of k -shortest routes connecting source and destination nodes is checked to know whether the amount of available frequency slots is equal to or higher than the required for the incoming connection request. If enough frequency slots are available in one of the shortest routes, the PCE calls the SPRESSO mechanism implemented inside the GCO to find a set of already established path reallocations so to make enough room for the connection request in the selected route (*newP*). Otherwise, the connection request is blocked. Figure 1a summarizes the routing and spectrum (re)allocation algorithm.

Figure 1b illustrates spectrum fragmentation on a test network; the entire spectrum width corresponds to 16 slots. Figure 1c represents the utilization of each frequency slot in the network, where a number of paths are already established. In this scenario, the connection request between nodes 4 and 7 requesting 4 slots cannot be served. Notwithstanding, each link in the shortest route 4-5-6-7 (links 4-5-6) has at least 4 free slots, and then the request could be established reallocating some of the established paths. In Figure 1d, paths p4 and p5 are reallocated making enough room for the new optical connection newP.

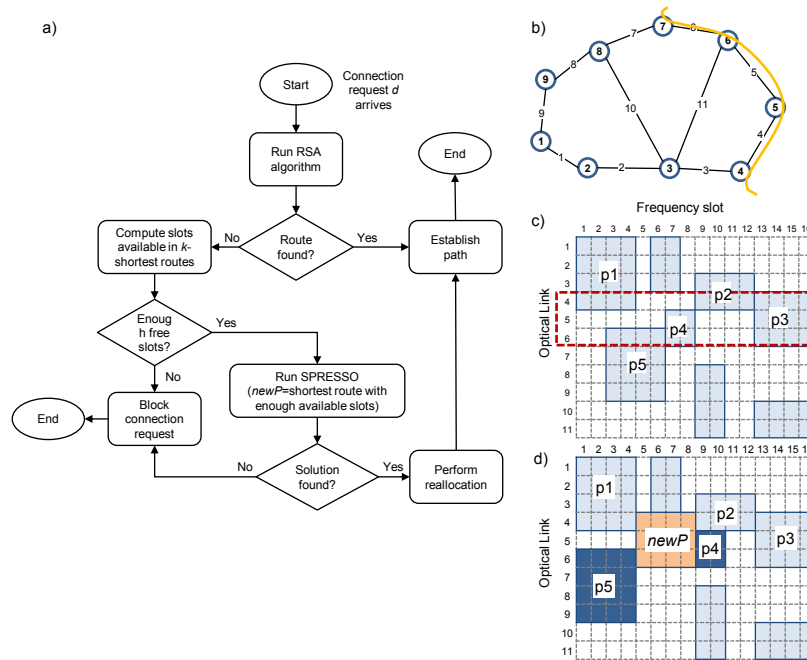

Figure 1. Example of the SPRESSO algorithm and spectrum reallocation.

3. DYNAMIC RESTORATION PROBLEM

In multilayer IP/MPLS-over-flexgrid, a failure in a single fiber link may disconnect tens or hundreds of client IP/MPLS flows. In that case, an independent restoration path computation request for each disconnected flow is received at the PCE. The standard procedure, i.e.: sequential, consists in computing a route for each request using the state of the network resources stored in the TED. However, better network-wide solutions can be achieved grouping together a set of path computation requests and performing bulk path computation.

In view that the sequential approach achieves poor resource efficiency and suffers from contention problems since path computations might be performed over a non-updated TED, we propose to take advantage of bulk path computation in restoration scenarios. To this end, we define the DYNAMIC restoration in Multi-layer IP/MPLS-over-flexgrid Optical networks (DYNAMO) [9] and solve it in a GCO module, which is called from a centralized PCE.

For illustrative purposes, Figure 2a shows a simple physical network consisting of five BV-OXCs and four IP/MPLS routers. BV-OXCs are connected by bidirectional fiber links. Let us assume that one MF-TP is installed in each of the IP/MPLS routers and connected to the collocated BV-OXC. Finally, two IP/MPLS client flows are already being served. We assume that the bitrate of each flow is 1 Gb/s. Two lightpaths were established in the physical topology to support an equal number of virtual links in the virtual topology. The route of each IP/MPLS flow over the virtual topology is given in the adjacent table.

At this stage, let us assume that a new IP/MPLS demand #3 between R1 and R3 need to be served. After requesting a route to the PCE it computes R1-R2-R3, where the existing virtual link R1-R2 is reused and a new virtual link R2-R3 must be created, which triggers the new lightpath R2-R3 to be established. Later, another IP/MPLS demand #4 between R2 and R3 arrives and it is served through the route R2-R3, using capacity available in virtual link R2-R3. Figure 2b describes the configuration of both the physical and the virtual topologies once all four IP/MPLS flows have been routed. Next, a failure in fiber link X1-X2 has triggered each of the affected flows (flows #1 and #3) to request a restoration route to the centralized PCE.

In Figure 2c the restoration route has been computed sequentially by the PCE and signaled afterwards. Since the TED in the PCE is only updated when the resources have been effectively allocated in the network, the signaling of the restoration routes of both IP/MPLS flows have triggered two parallel lightpaths to be set-up so as to create the virtual links needed to route the IP/MPLS flows. In the example, both lightpaths could be created because enough resources, i.e. frequency slots in the links and ports in the IP/MPLS routers, were available. Frequently, nonetheless, that is not the case and *resource contention* may arise. In that regard, note that both restoration routes reused the virtual link R1-R4; again resource contention could arise as a consequence of not enough capacity being available for both IP/MPLS flows in that virtual link.

In Figure 2d the PCE has grouped all restoration requests and performed bulk route computation. In the example, the restoration route of both IP/MPLS flows has been computed. The bulk routing algorithm decides to create virtual link R4-R2 using that for both restoration routes, thus reducing the amount of resources used

compared to the sequential approach. However, for the bulk restoration to work restoration routes need to be sequenced: one

of the routes must be signaled first, so as to trigger actual virtual link creation; after waiting enough time, virtual link R4-R2 is effectively created and the second route reusing it can be signaled.

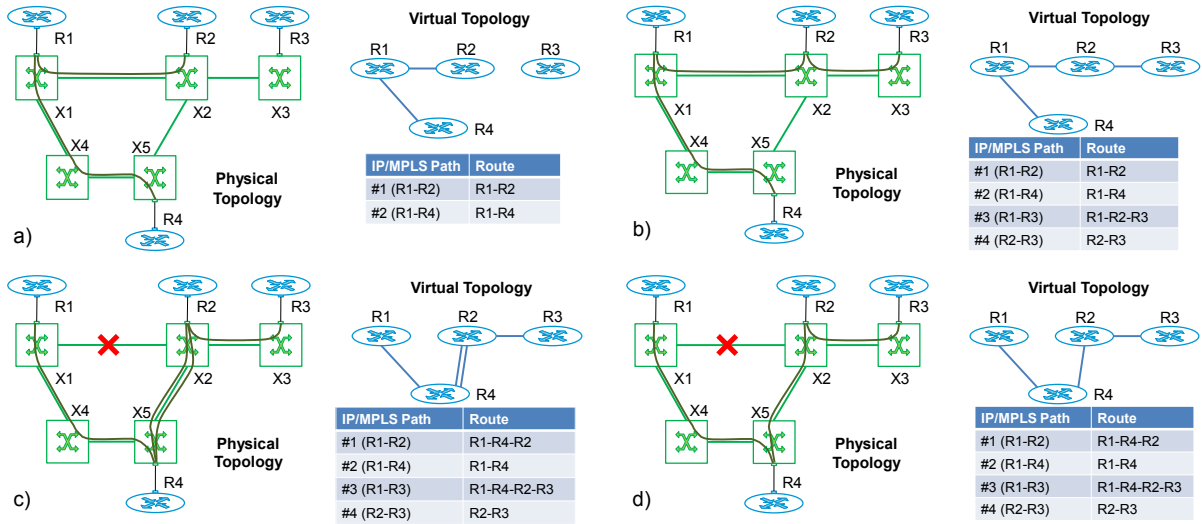

Figure 2. Example of multilayer network consisting in five BV-OXCs and four IP/MPLS routers.

As anticipated above, for the bulk restoration to work properly, computed routes must be sequenced for signaling so as to allow that new virtual links are firstly created, and their lightpaths established, by one IP/MPLS demand; after that their capacity is available to be reused by other IP/MPLS flows. In our example, flows #1 and #3 need virtual link R4-R2 to be created. Then, one of the demands is rerouted and the other one must be delayed enough to allow the virtual link R4-R2 to be effectively created. This fact introduces a set of dependences among the demands that must be considered so as to minimize recovery times.

4. RESULTS

To evaluate the performance of the considered approaches we developed an ad-hoc event-driven simulator. Table I summarizes the gain of using SPRESSO for the Spanish Telefónica (TEL) network topology, traffic profile, and slot width [8]. Presented values are for $Pb_{bw} = 1\%$. Interestingly, spectrum reallocation provides only a gain in the order of 10% for all the network topologies under TP-1 when slots of 50 GHz are used; recall that in such a scenario, all connections request only one slot and then spectrum fragmentation is as a consequence of the spectrum continuity constraint (similarly to WDM). As soon as the slot width is decreased, the diversity in the number of contiguous slots requested increases and, since also slot contiguity is required, the spectrum fragmentation increases. In these scenarios, especially in TPs 2-6 where the amount of requests for 400Gb/s is important, SPRESSO provides improvements in the range between 20% and 31%. These results verify the goodness of our proposed mechanism.

Table I. Gain of using SPRESSO ($Pb_{bw}=1\%$).

	Average TP	50 GHz	25 GHz	12.5 GHz	6.25 GHz
TP-1	21.6%	10.7%	17.8%	28.2%	29.7%
TP-2	29.4%	32.8%	23.3%	23.4%	38.1%
TP-3	30.9%	33.3%	29.6%	29.5%	31.2%
TP-4	31.7%	35.5%	26.7%	32.7%	32.1%
TP-5	28.0%	32.2%	28.6%	25.0%	26.3%
TP-6	29.4%	30.4%	28.4%	30.3%	28.5%

Table II gives insight on the results for the TEL network using MF-TP with capacity for 5 lightpaths. There, the amount of IP/MPLS flows to be restored ranges, on average, from 37 to 46 as a function of the load offered to the network. Un-restorability values are given for both, the sequential and the bulk approach. Two main causes behind un-restored flows are detailed: *i*) no route could be found during path computation; and *ii*) resource contention, i.e. resources where already in use during the signaling phase. The latter gets together frequency slots and existing virtual links that were available in the TED when the route was computed, or MF-TPs resources that are actually allocated during lightpaths' set-up. As detailed, the reason for the high un-restorability of the

sequential approach is resource contention; restoration routes are computed using the state of the resources in the TED, however, as a result of the number of path computation requests arriving at the PCE, the TED becomes immediately outdated and thus both, the same resources could be assigned to several routes, and ports

Table II. Restoration Results for the TEL Network Using 5-Lightpath MF-TPs.

Offered Load	# flows to restore	Un-restorability Sequential			Un-restorability Bulk		
		Total	Path Computation	Resource contention	Total	Path Computation	Resource contention
357	37.14	47.72%	0.00%	47.72%	0.02%	0.02%	0.00%
378	39.98	50.10%	0.00%	50.10%	0.13%	0.13%	0.00%
383	40.71	49.11%	0.00%	49.11%	0.13%	0.13%	0.00%
395	43.28	51.95%	0.00%	51.95%	0.21%	0.21%	0.00%
409	46.59	53.21%	0.00%	53.21%	0.56%	0.56%	0.00%

availability decreases notably so no new lightpaths could be established. The bulk restoration approach, in contrast, reaches negligible un-restorability values since network resources are globally optimized. Once, restoration routes are computed for a bulk of requests, resource contention disappears completely.

5. CONCLUSIONS

In this paper we presented two use cases that take advantage of the PCE+GCO architecture: the SPRESSO and the DYNAMO.

The SPRESSO mechanism was proposed to reallocate already established paths in the spectrum, so to make enough room for a new incoming connection request. The SPRESSO mechanism was afterwards implemented in our simulator improving the performance of the networks in a range from 20 to 31%. Here, the make-before-break method to avoid disruption can also be used. Undoubtedly, the SPRESSO mechanism provides high benefits in terms of increment of traffic. Exhaustive simulation results show that blocking probability reductions in the range 20 – 31% are obtained without increasing the cost of the network.

The bulk restoration approach in multilayer IP/MPLS-over-flexgrid networks was proposed in this paper. To this end, DYNAMO problem was presented. The focus of the latter was in obtaining the highest effectiveness in terms of the objective function (maximize restorability, minimizing the amount of resources used and dependence depth). The performance of the approach was extensively assessed on two national network topologies, using an ad-hoc network simulator. The results obtained showed that the bulk restoration approach is able to restore almost all the disconnected IP/MPLS flows.

To conclude the paper, it is worth highlighting the standardization initiatives currently on-going in the IETF to allow the PCE to modify parameters of already established LSPs [10]. That feature will favour the above use cases to be actually implemented in the control plane of flexgrid networks.

ACKNOWLEDGEMENTS

This work has been partially funded by the European Community's Seventh Framework Programme FP7/2007-2013 under grant agreement n° 317999 IDEALIST project and from the Spanish Science Ministry through ELASTIC (TEC2011-27310) project.

REFERENCES

- [1] M. Jinno *et al.*, "Spectrum-efficient and scalable elastic optical path network: architecture, benefits, and enabling technologies," *IEEE Comm. Mag.* vol. 47, pp. 66-73, 2009.
- [2] O. Gerstel, M. Jinno, A. Lord, S. Ben Yoo, "Elastic optical networking: A new dawn for the optical layer?" *IEEE Commun Mag.*, vol. 50, pp. s12-s20, 2012.
- [3] O. Pedrola *et al.*, "CAPEX study for multilayer IP/MPLS over flexgrid optical network," *IEEE/OSA J. Opt. Comm. and Netw. (JOCN)*, vol. 4, pp. 639-650, 2012.
- [4] M. Jinno, H. Takara, Y. Sone, K. Yonenaga, A. Hirano, "Multiflow optical transponder for efficient multilayer optical networking," *IEEE Commun Mag.*, vol. 50, pp. 56 -65, 2012.
- [5] L. Velasco, P. Wright, A. Lord, and G. Junyent, "Designing national IP/MPLS networks with flexgrid optical technology," accepted in *OSA Optics Express*, 2013.
- [6] A. Farrel, J.P. Vasseur, J. Ash, "A Path Computation Element (PCE)-Based Architecture," IETF RFC-4655, 2006.
- [7] Y. Lee *et al.*, "Path Computation Element Communication Protocol (PCEP) Requirements and Protocol Extensions in Support of Global Concurrent Optimization," IETF RFC-5557, 2009.
- [8] A. Castro *et al.*, "Dynamic routing and spectrum (re)allocation in future flexgrid optical networks," *Elsevier Computers Networks*, vol. 56, pp. 2869-2883, 2012.
- [9] A. Castro, L. Velasco, J. Comellas, G. Junyent, "Dynamic restoration in multi-layer IP/MPLS-over-flexgrid networks," in *Proc. IEEE Design of Reliable Communication Networks (DRCN)*, 2013.
- [10] E. Crabbe, J. Medved, R. Varga, and I. Minei, "PCEP Extensions for Stateful PCE," IETF draft, Mar. 2013.