



UNIVERSITAT POLITÈCNICA
DE CATALUNYA

Optical
Communications
Group



Design and Re-optimization Algorithms for Elastic Optical Networks

Luis Velasco
lvelasco@ac.upc.edu



Outline

- I. RSA Basics**
- II. Network Design**
- III. RSA under Dynamic Traffic**
- IV. Extending networks life-cycle**
- V. Towards Cognitive Networking**



UNIVERSITAT POLITÈCNICA
DE CATALUNYA

Optical
Communications
Group



Part I

RSA basics

Luis Velasco

Elastic Optical Networks

- Flexgrid uses a finer spectrum granularity.
 - The optical spectrum is divided into frequency slices (e.g. 12.5GHz).
- It brings features that are not offered by the fixed grid networks, such as
 - **flexible** bandwidth allocation.
 - transporting optical connections with a capacity **beyond 100Gb/s**
 - **elasticity** against time-varying traffic.

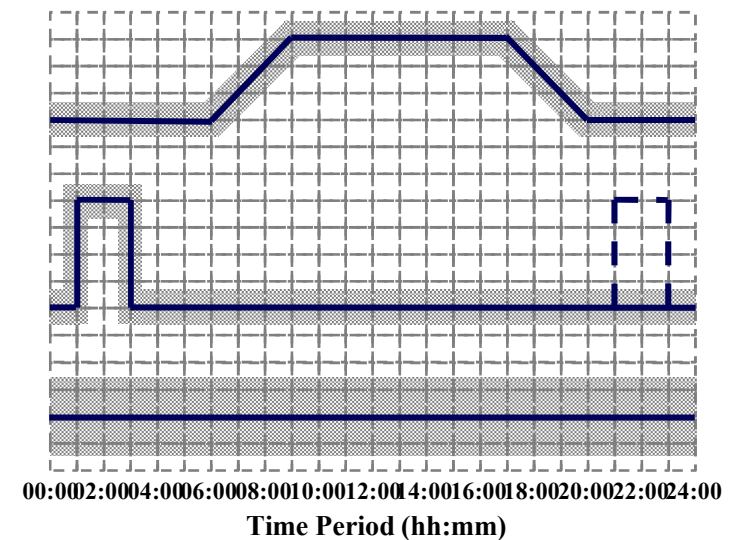
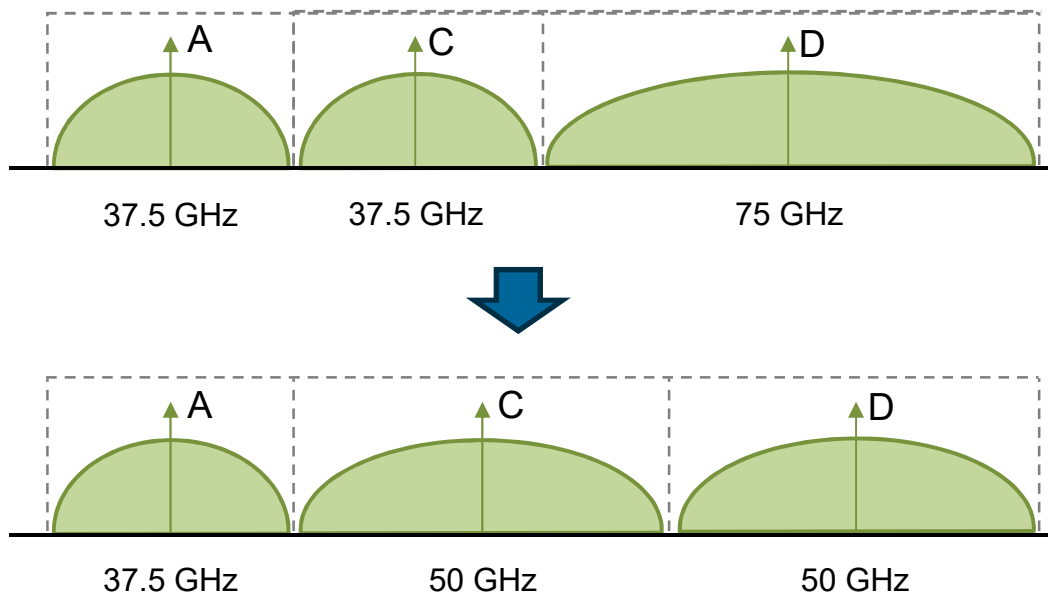

Spectrum allocation

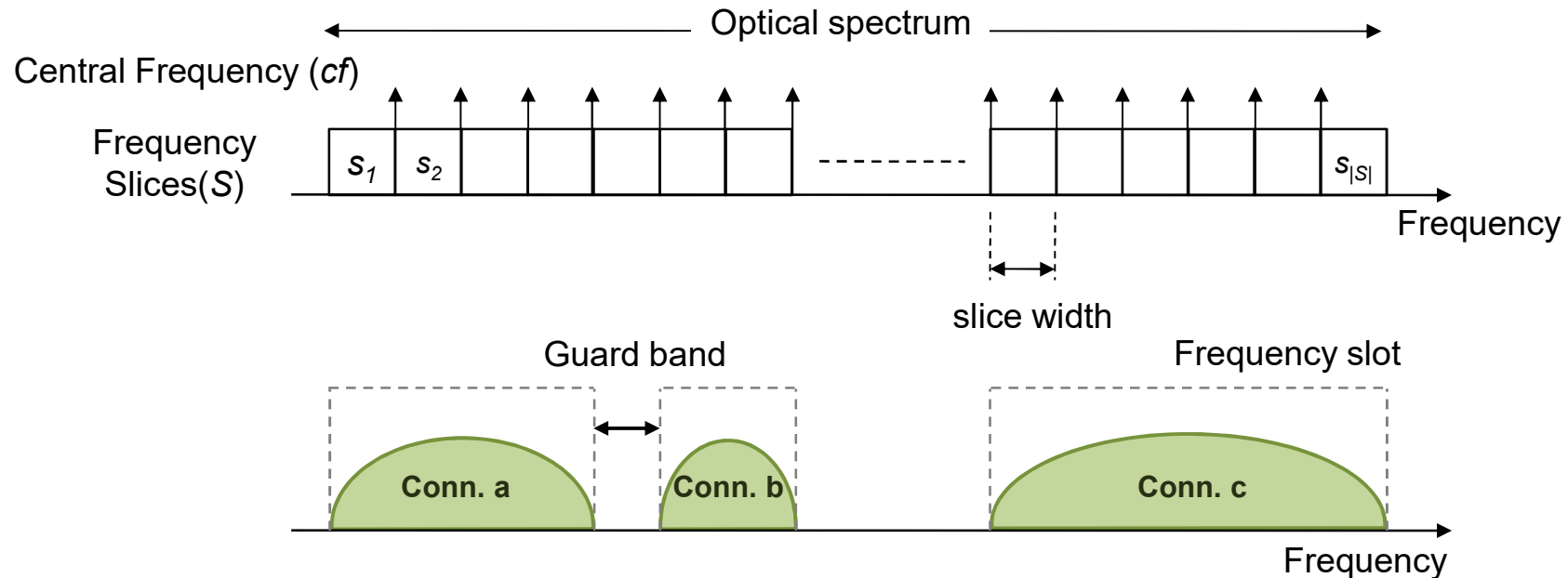

Spectrum allocation entail dealing with two constraints:

- **spectrum continuity** along the links of a given routing path: the same slices must be used in all links of the path,
- **spectrum contiguity**: the allocated slices must be contiguous in the spectrum.

Slices and Slots

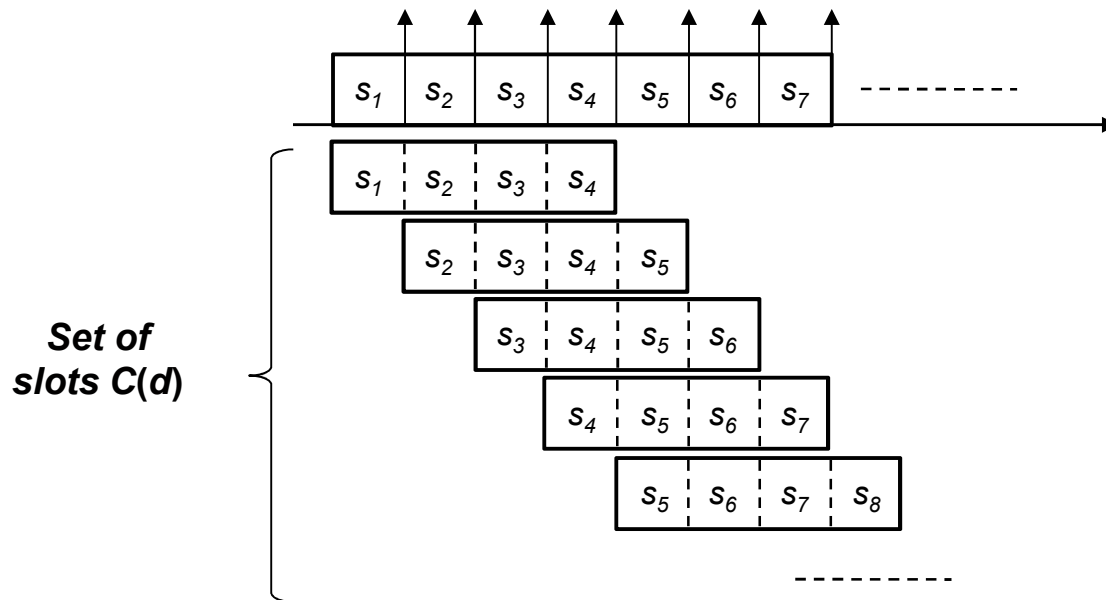
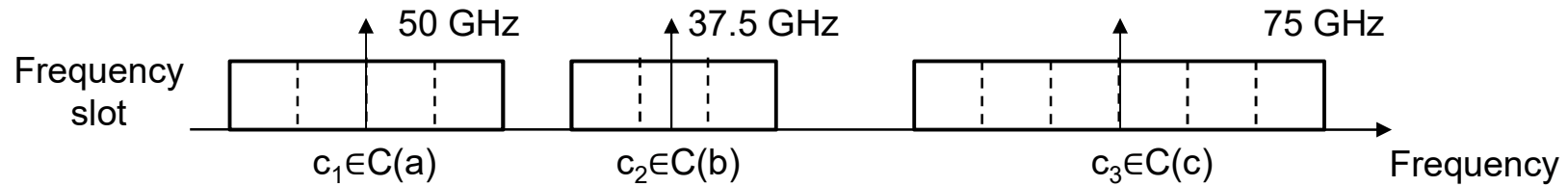

$C(d)$ pre-computation

INPUT S, d	
OUTPUT $C(d)$	
1:	Initialize: $C(d) \leftarrow 0_{[S -n_d+1 \times S]}$
2:	for each i in $[0, S -n_d]$ do
3:	for each s in $[i, i+n_d-1]$ do
4:	$C(d)[s]=1$
5:	return $C(d)$

Basic RSA Problem Statement

- Given:
 1. a graph $G(N,E)$, where N is the of nodes and a set of optical fibers E connecting those nodes;
 2. the characteristics of the optical spectrum (i.e., spectrum width, frequency slice width) and the set of modulation formats;
 3. a traffic matrix D with the amount of bitrate exchanged between each pair of locations in N ;
- Output: the **Route and Spectrum Allocation** for each demand in D .
- Objective: one or more among:
 - Minimize the amount of bitrate blocked,
 - Minimize the total amount of used slices,
 - Minimize the total number of links used,
 - etc.

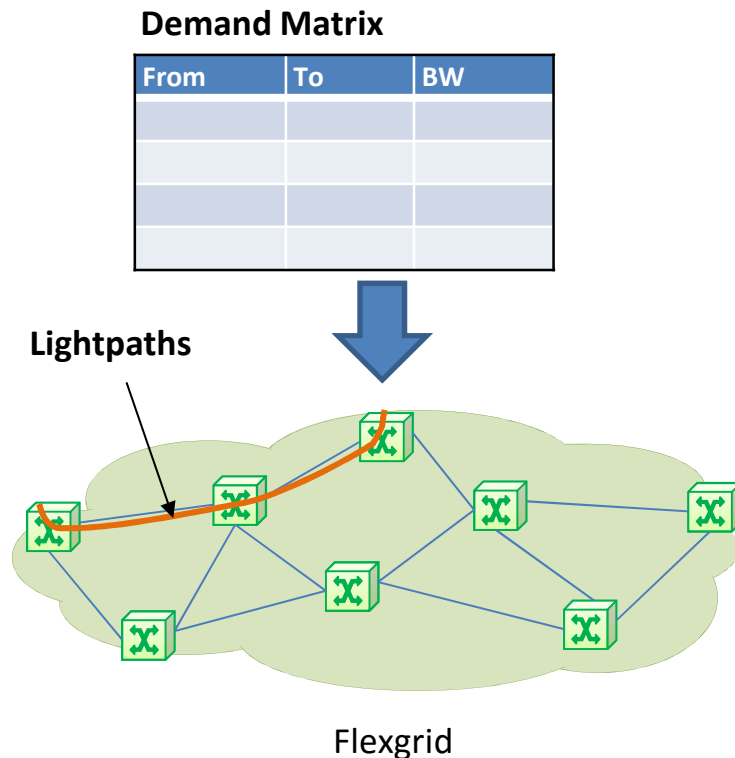

Link-path Slot Assignment Formulation

Pre-computed Parameters

- $P(d)$ Set of predefined candidate paths for demand d .
- $C(d)$ Set of slots for demand d .
- δ_{pe} Equal to 1 if path p uses link e , 0 otherwise.
- γ_{cs} Equal to 1 if slot c includes slice s , 0 otherwise.

Variables

- x_d Binary. Equal to 1 if demand d is rejected, 0 otherwise.
- y_{pc} Binary. Equal to 1 if slot c is assigned to path p and 0 otherwise

(LP - CA) $\min \sum_{d \in D} x_d \cdot b_d$

$O(|P(d)| \cdot |D| \cdot |C|)$ variables
 $O(|D| + |E| \cdot |S|)$ constraints

subject to:

$$\sum_{p \in P(d)} \sum_{c \in C(d)} y_{pc} + x_d = 1 \quad \forall d \in D$$

$$\sum_{d \in D} \sum_{p \in P(d)} \sum_{c \in C(d)} \gamma_{cs} \cdot \delta_{pe} \cdot y_{pc} \leq 1 \quad \forall e \in E, s \in S$$

Solved using CPLEX

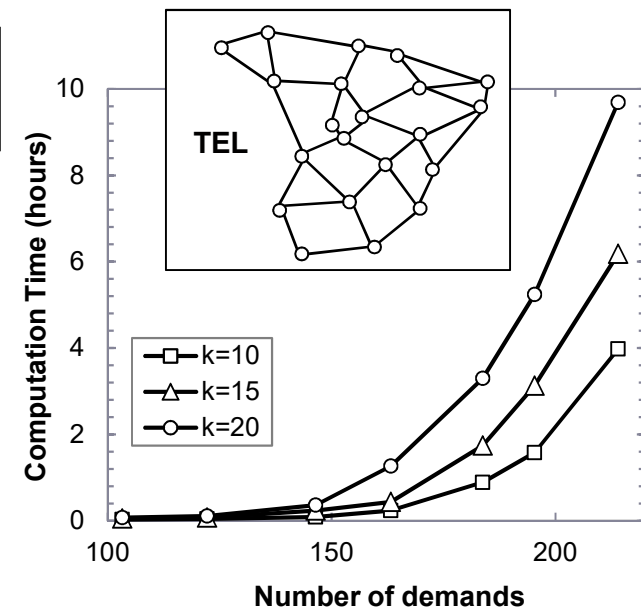

* L. Velasco et al., "Solving Routing and Spectrum Allocation Related Optimization Problems: from Off-Line to In-Operation Flexgrid Network Planning," (Invited Tutorial) IEEE/OSA Journal of Lightwave Technology (JLT), vol. 32, pp. 2780-2795, 2014.

Topology Design as a RSA Problem

- Given:
 1. a connected graph $G(N,E)$, where N is the set of locations and E the set of optical fibers that can be used;
 2. the characteristics of the optical spectrum and modulation formats;
 3. a traffic matrix D ;
- Output:
 1. The route and spectrum allocation for each demand in D .
 2. **The links that need to be equipped;**
- Objective: **Minimize number of links to be equipped** to transport the given traffic matrix.

Node-link SA Formulation

Variables

- w_{dec} Binary. Equal to 1 if demand d uses slot c in link e , 0 otherwise
 z_e Binary. Equal to 1 if link e is opened, 0 otherwise

$$(NL - CA) \quad \min \quad \sum_{e \in E} z_e$$

subject to:

$$\sum_{e \in E(v)} \sum_{c \in C(d)} w_{dec} = 1 \quad \forall d \in D, v \in \{s_d, t_d\}$$

$$\sum_{e \in E(v)} \sum_{c \in C(d)} w_{dec} \leq 2 \quad \forall d \in D, v \notin \{s_d, t_d\}$$

$$\sum_{\substack{e' \in E(v) \\ e' \neq e}} w_{de'c} \geq w_{dec} \quad \forall d \in D, c \in C(d), v \notin \{s_d, t_d\}, e \in E(v)$$

$$\sum_{d \in D} \sum_{c \in C(d)} \gamma_{cs} \cdot w_{dec} \leq 1 \quad \forall e \in E, s \in S$$

$$\sum_{d \in D} \sum_{c \in C(d)} w_{dec} \leq |S| \cdot z_e \quad \forall e \in E$$

$O(|D| \cdot |E| \cdot |C|)$ variables

$O(|D| \cdot |C| \cdot |N| \cdot |E|)$ constraints

* L. Velasco et al., "Solving Routing and Spectrum Allocation Related Optimization Problems: from Off-Line to In-Operation Flexgrid Network Planning," (Invited Tutorial) IEEE/OSA Journal of Lightwave Technology (JLT), vol. 32, pp. 2780-2795, 2014.

Network Dimensioning as a RSA Problem

- Given:
 1. a connected graph $G(N,E)$, where N is the set of locations and E the set of optical fibers;
 2. the characteristics of the optical spectrum and modulation formats;
 3. a traffic matrix D ;
 4. **the cost of every component, such as optical cross-connects (OXC) and transponder (TP) types specifying its capacity and reach.**
- Output:
 1. The route and spectrum allocation for each demand in D .
 2. **Network dimensioning including the type of OXC and TPs in each location;**
- Objective: **Minimize the total cost** to transport the given traffic matrix.



UNIVERSITAT POLITÈCNICA
DE CATALUNYA

Optical
Communications
Group



Part II

Network Design

Luis Velasco

Classical Network life-cycle

- Network planning is performed periodically:

- **Capacity** is installed to guarantee that the network can support the forecast traffic.
- **Long planning cycles** are used to upgrade the network and prepare it for the next planning period.
- Results from network capacity planning are **manually deployed** in the network.

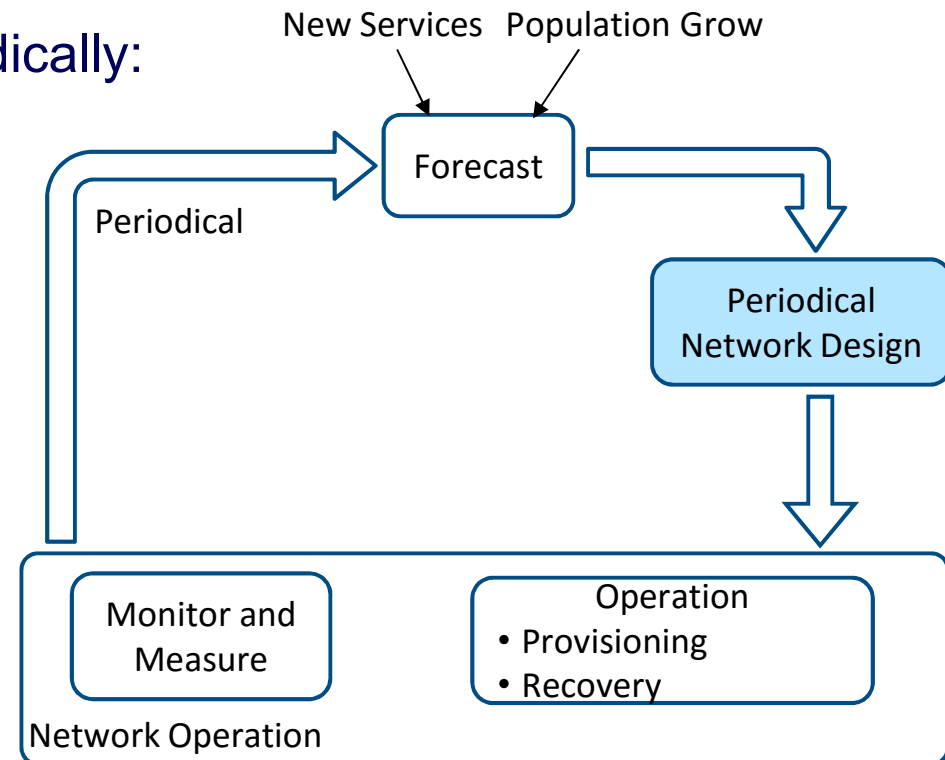

Designing National IP/MPLS Networks with Flexgrid Optical Technology

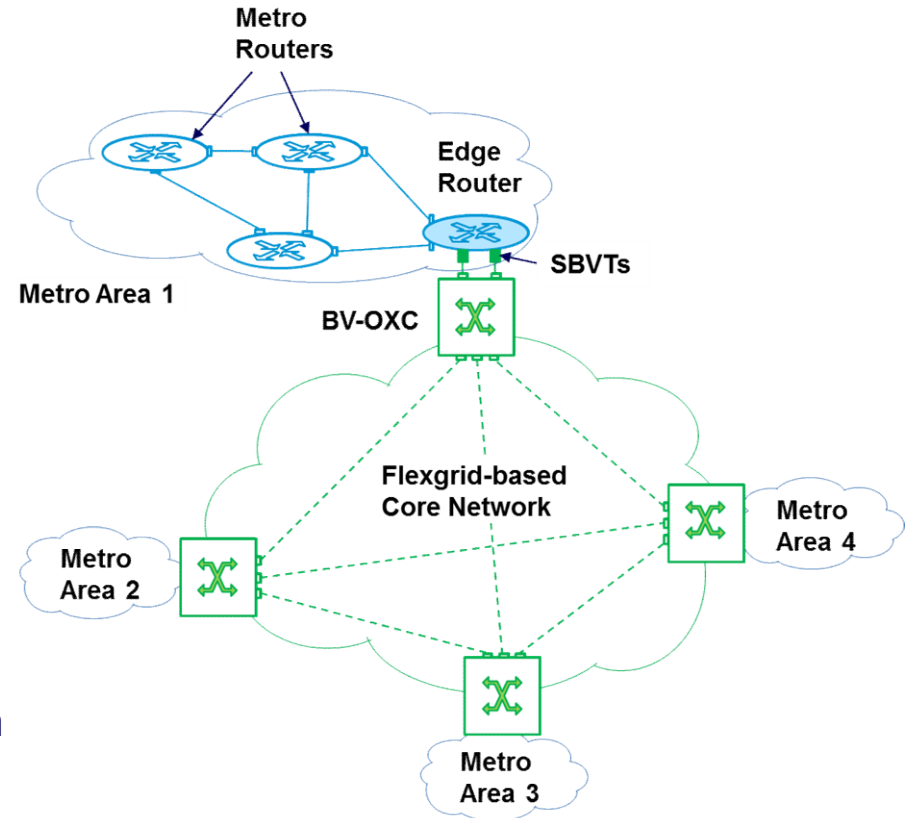
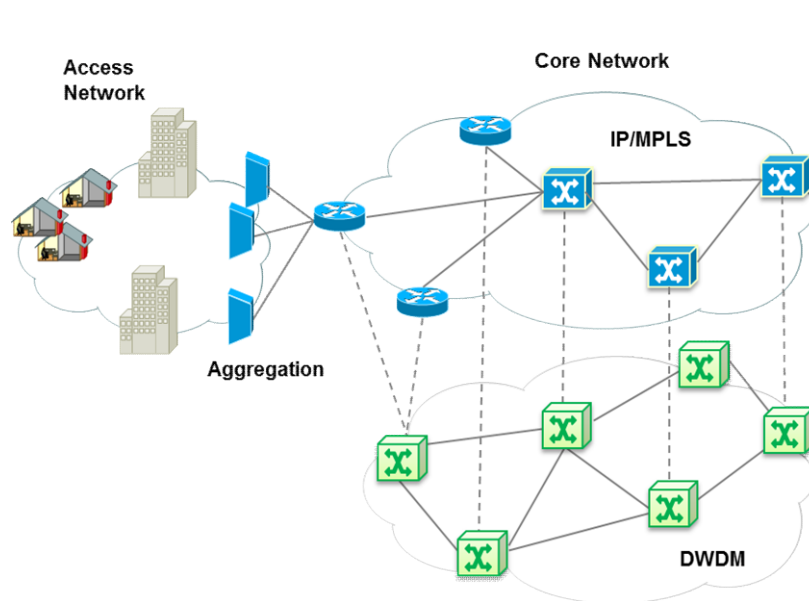

National IP/MPLS networks have been built on the top of optical networks, and thus the design problem has been typically addressed through a **multilayer IP/MPLS-over-optical** approach.

The multilayer approach is transformed into a single-layer approach where a number of **IP/MPLS metro area networks** performing aggregation are connected through a **flexgrid-based core network**.

* L. Velasco et al., "Saving CAPEX by Extending Flexgrid-based Core Optical Networks towards the Edges," IEEE/OSA Journal of Optical Communications and Networking (JOCN), vol. 5, pp. A171-A183, 2013.

Flexgrid-based Network Design

- The flexgrid-based network design consists in designing a complete network including metro and core networks so as to deploy spectrum-efficient core network.

- We define network spectrum efficiency as:
$$\sum_{a \in A} \sum_{\substack{a' \in A \\ a' \neq a}} \frac{b_{aa'}}{\Delta f \cdot B_{\text{mod}}} \bigg/ \sum_{a \in A} \sum_{\substack{a' \in A \\ a' \neq a}} \left[\frac{b_{aa'}}{\Delta f \cdot B_{\text{mod}}} \right]$$

- Two phases are considered:

1. Partitioning the Network in Metro Areas: The complete set of locations is grouped into a number of metro areas. The core network convey aggregated flows between metro areas. The slot width used in the flexgrid-based core network is taken into account to guarantee enough spectral efficiency.

2. Metro and Core networks design.

- Set of locations
- Potential metros
- Traffic matrix
- Slice width

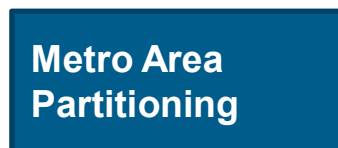

- Traffic Matrices
- Metro Areas



Design for each network



Network Graphs,
Equipments and costs

Area Partitioning Problem

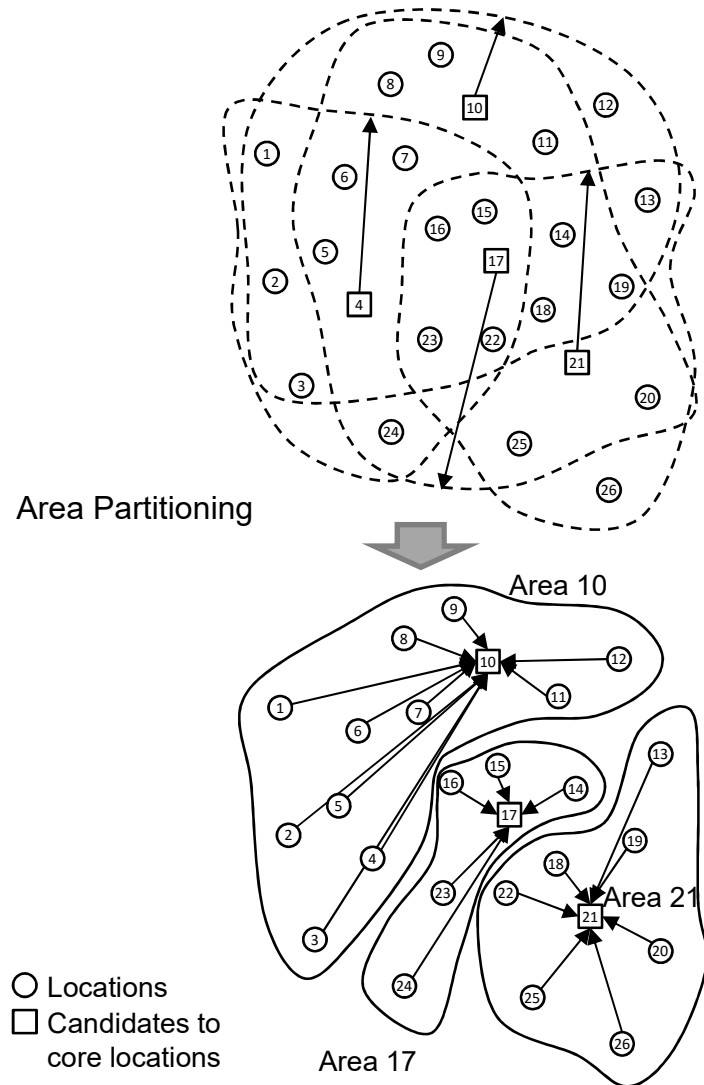

Given:

- a set L of Locations,
- a subset $A \subseteq L$ of locations that can be selected as core locations. Since each core location $a \in A$ could entail an area to be created, the set A also represents the set of areas,
- the subset $A(l) \subseteq A$ of core locations where each location l can belong to,
- the location-to-location traffic matrix,
- the considered slice width (Δf) for the flexgrid network.

Output: The set of areas. For each area a , the locations belonging to that area and its internal traffic. The set of aggregated traffic between areas ($b_{aa'}$).

Objective: Maximize the aggregated traffic exchanged between areas ($\sum_{a \in A} \sum_{a' \in A} b_{aa'}$) subject to ensuring a minimum spectral efficiency for the core network.

* L. Velasco et al. "Saving CAPEX by Extending Flexgrid-based Core Optical Networks towards the Edges," IEEE/OSA JOCN, vol. 5, pp. A171-A183, 2013.

Network Design Problem

Given:

- a network topology represented by a graph $G_C(N_C, L)$, being N_C the set of core locations and L the set of fibre links connecting two locations,
- a set S of available slices of a given spectral width for each link in L ,
- a set D_C of IP/MPLS demands to be transported,
- BV-OXC cost, which include a fixed cost for common hardware and a variable cost that depends on the nodal degree and the number of local ports (patch panels can be used to connect optical fibres provided that no local signals are dropped); a cost for every optical amplifier (OA) to be equipped in the used fibre links; a cost of every 3R needed to electronically regenerate optical signals at intermediate nodes. Different types of 3Rs may exist as a function of their capacity and reach.

Output:

- the optical network, including patch panels, BV-OXCs and its configuration, OA and fibres,
- the location and capacity of each of the 3Rs needed.

Objective: Minimize the expected CAPEX for the core network designed for the given set of demands.

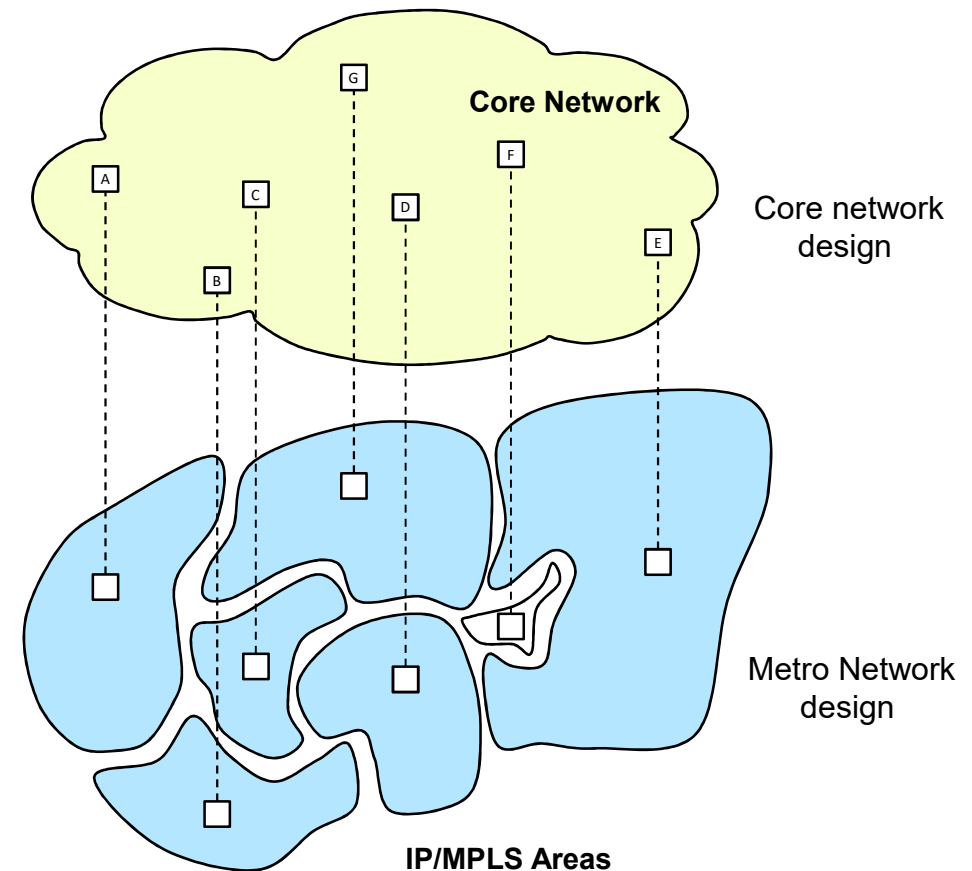

Design results

Aggregated and breakdown IP/MPLS CAPEX.

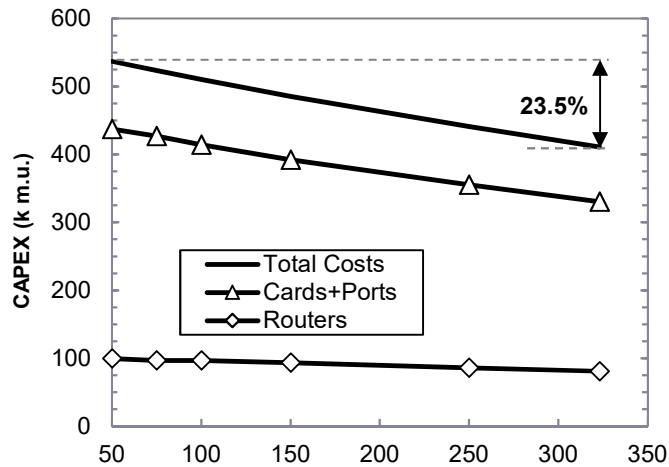

Flexgrid core network CAPEX for each considered slot width.

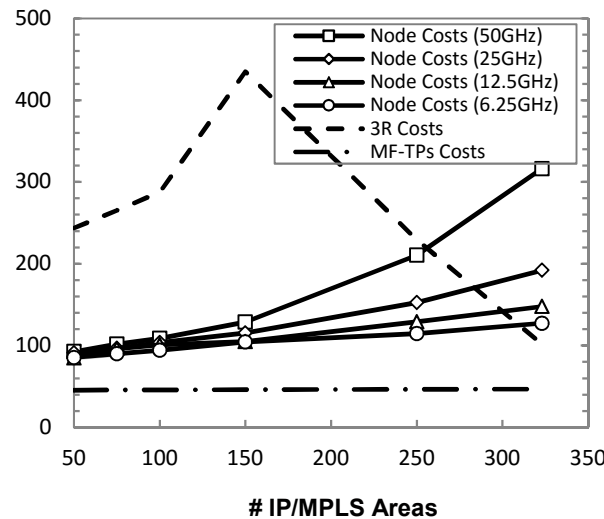

Core network costs breakdown

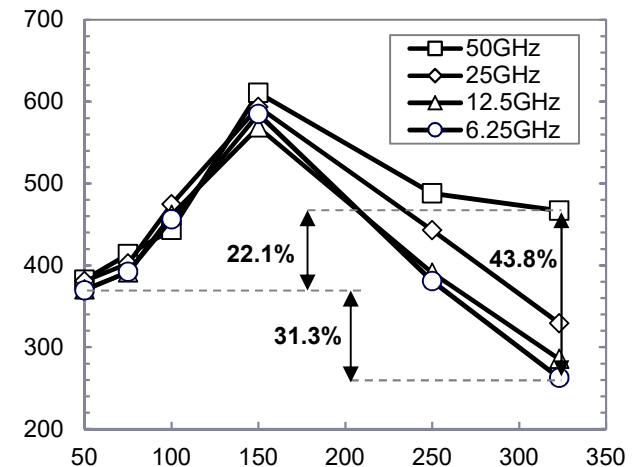

- Significant savings can be obtained when the core network extends towards the edges increasing the number of areas that are connected.
 - 31% at the flexgrid core network
 - 23% at the IP/MPLS networks
- The flexgrid core network need to use finer slices (12.5 or even 6.25 GHz)
 - grooming is done, in part, at the optical layer considerably reducing that done at the IP/MPLS one.
 - The capacity and the number of IP/MPLS routers and ports can be reduced.
- 3R regeneration is needed as a result of super-channels, e.g. 400Gb/s
 - it might be mitigated by using e.g. 4x100Gb/s, increasing thus the reach of the optical signals.

SBVTs under Static traffic

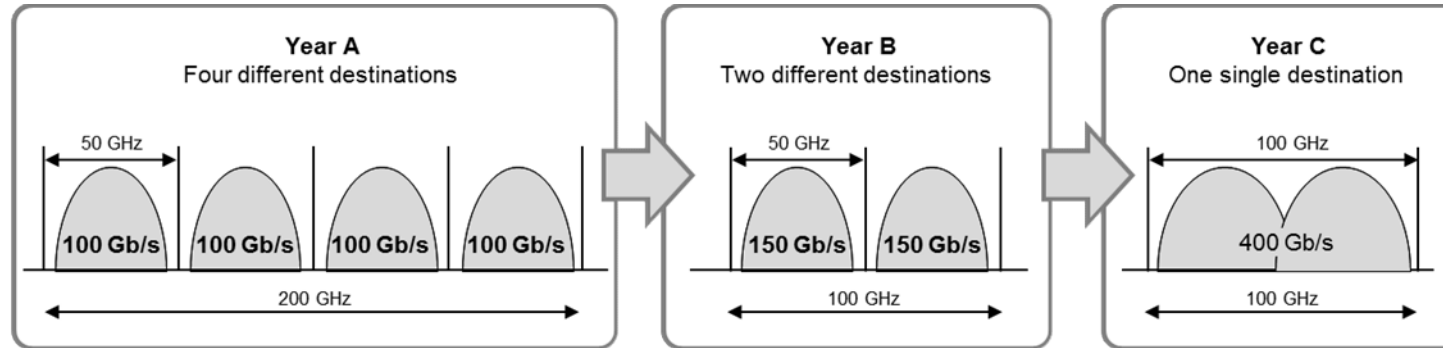

Gb/s	Y1	Y2	Y3	Y4	Y5	Y6	Y7	Y8	Y9	Y10
<=100	85.7%	61.9%	47.6%	33.3%	19.0%	19.0%	4.8%	4.8%	4.8%	4.8%
(100-200]	14.3%	33.3%	42.9%	52.4%	61.9%	42.9%	28.6%	14.3%	14.3%	0.0%
(200-300]	0.0%	4.8%	9.5%	9.5%	9.5%	23.8%	28.6%	28.6%	9.5%	14.3%
(300-400]	0.0%	0.0%	0.0%	4.8%	4.8%	4.8%	23.8%	33.3%	33.3%	14.3%
>400	0.0%	0.0%	0.0%	0.0%	4.8%	9.5%	14.3%	19.0%	38.1%	66.7%

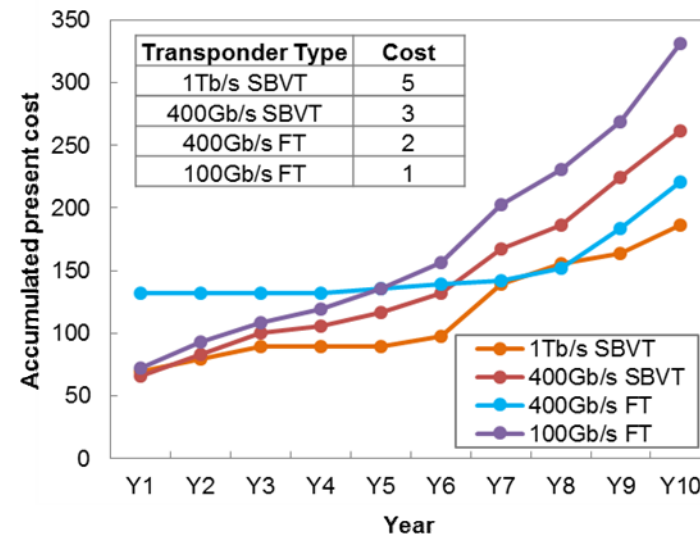
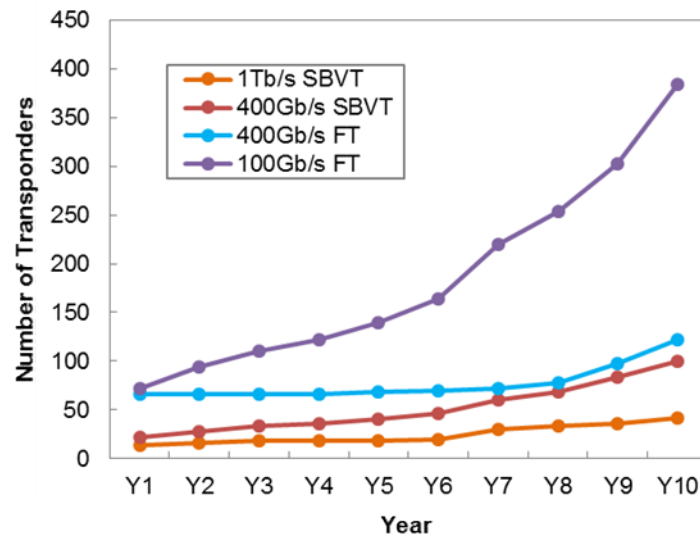

Migrating Towards Flexgrid Technology

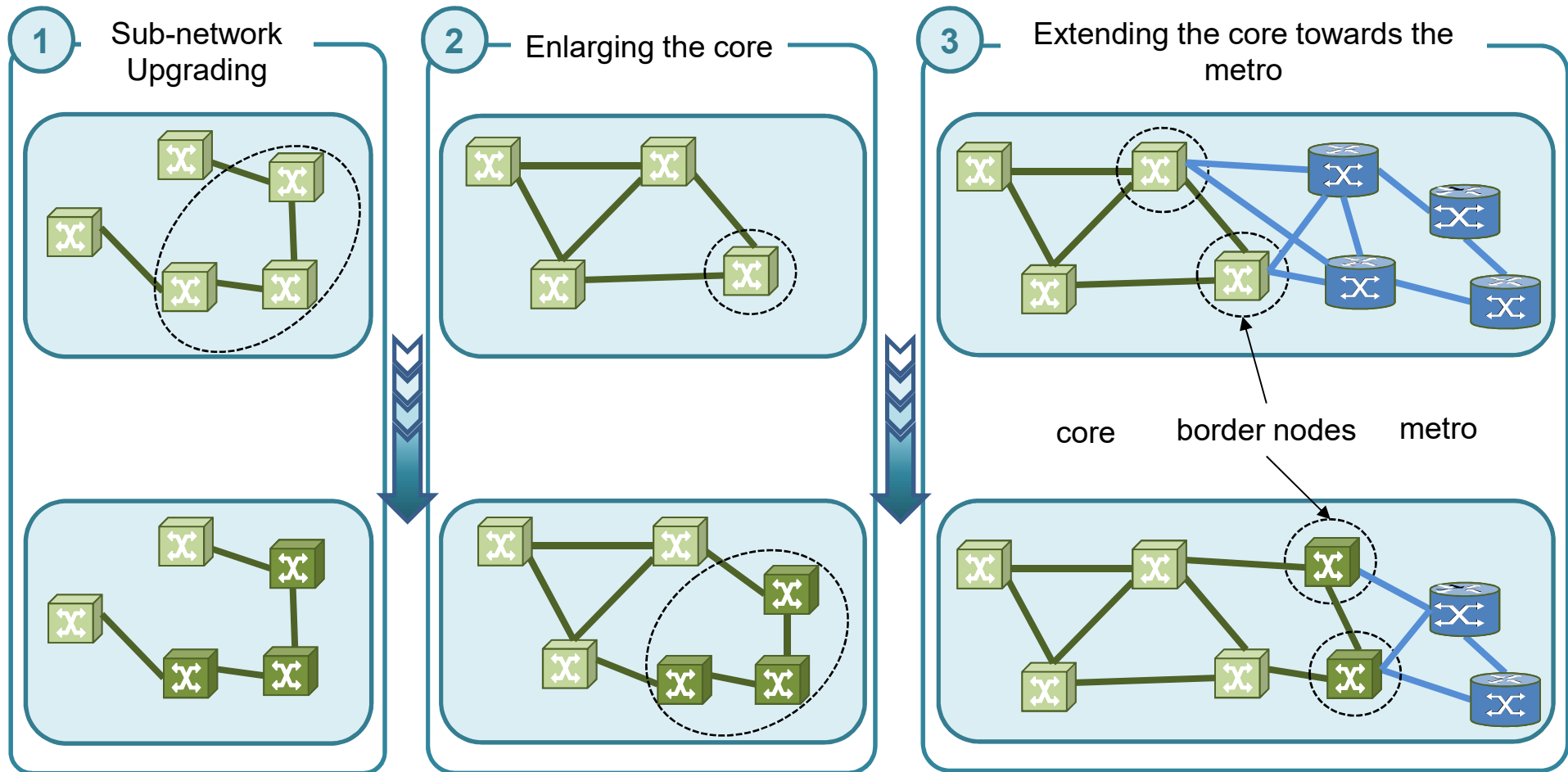

* M. Ruiz et al, "Planning Fixed to Flexgrid Gradual Migration: Drivers and Open Issues," IEEE Communications Magazine, vol. 52, pp. 70-76, 2014.

Migrating connections

Fixed grid

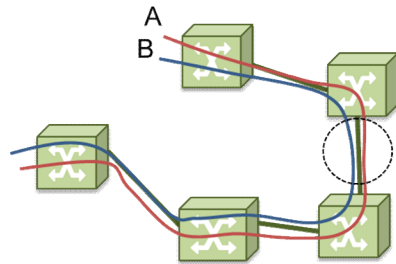

Flexgrid

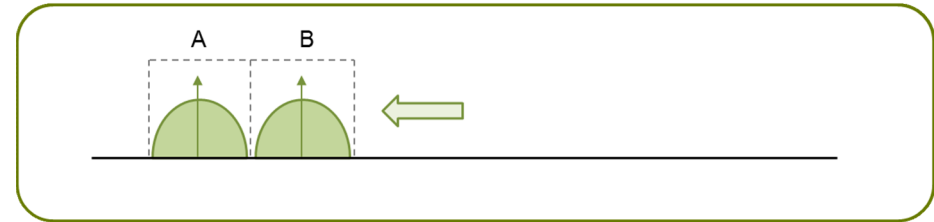
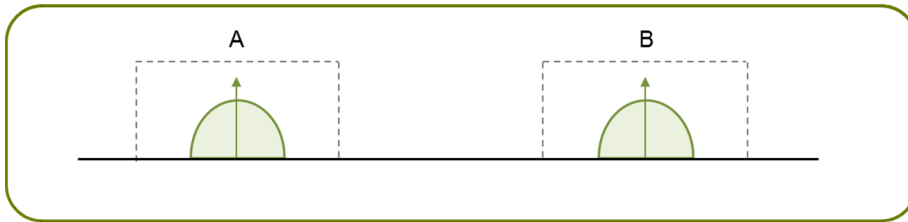
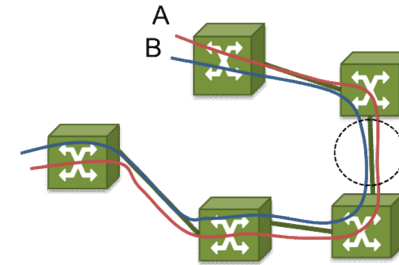

Mixed grid

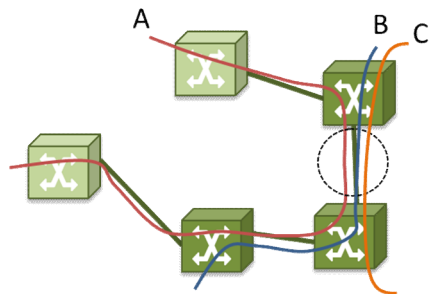

Mixed grid

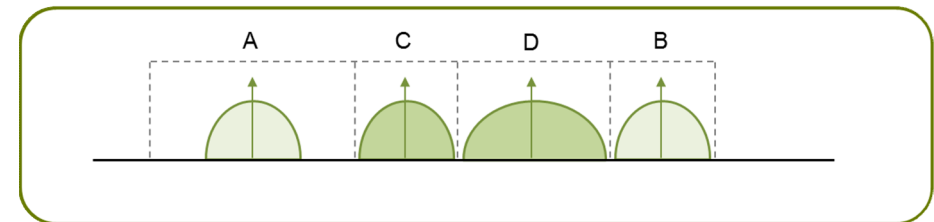
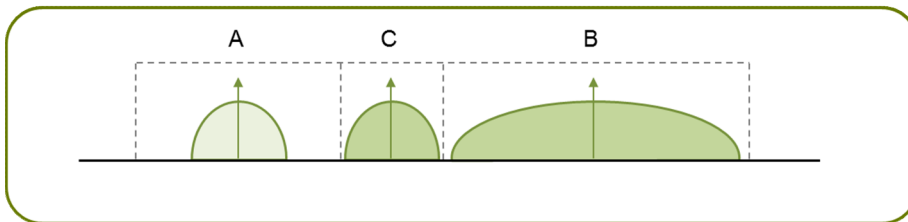
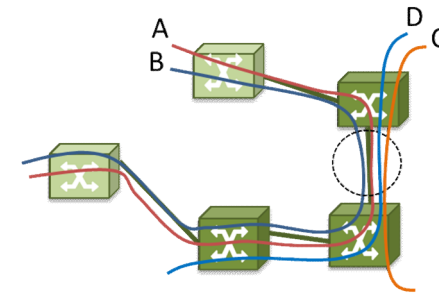

Migration flow chart

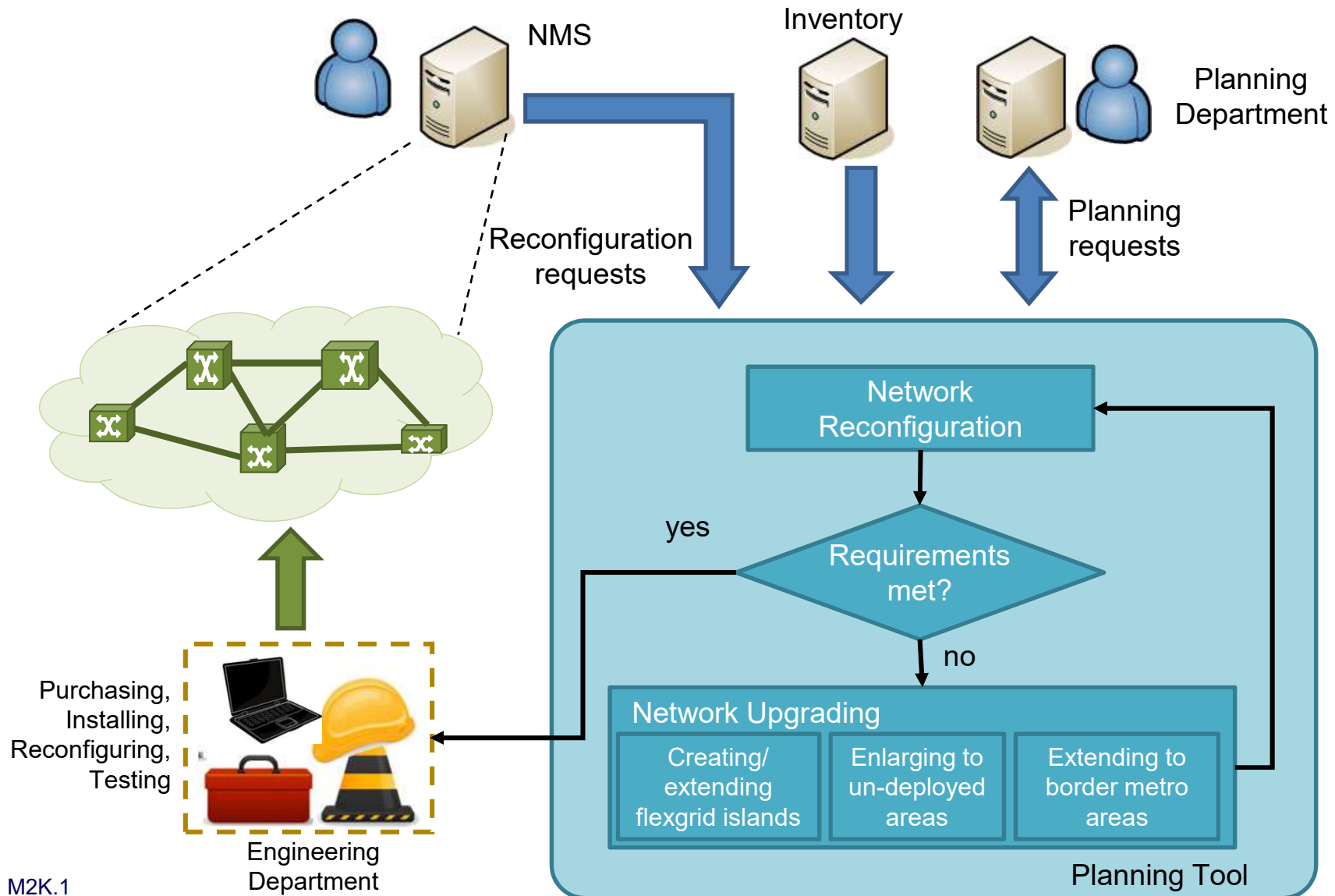



UNIVERSITAT POLITÈCNICA
DE CATALUNYA

Optical
Communications
Group



Part III

RSA under Dynamic Traffic

Luis Velasco

Source of traffic variations

Reducing aggregation level might increase traffic variations

Datacenter interconnection to transfer bulk data

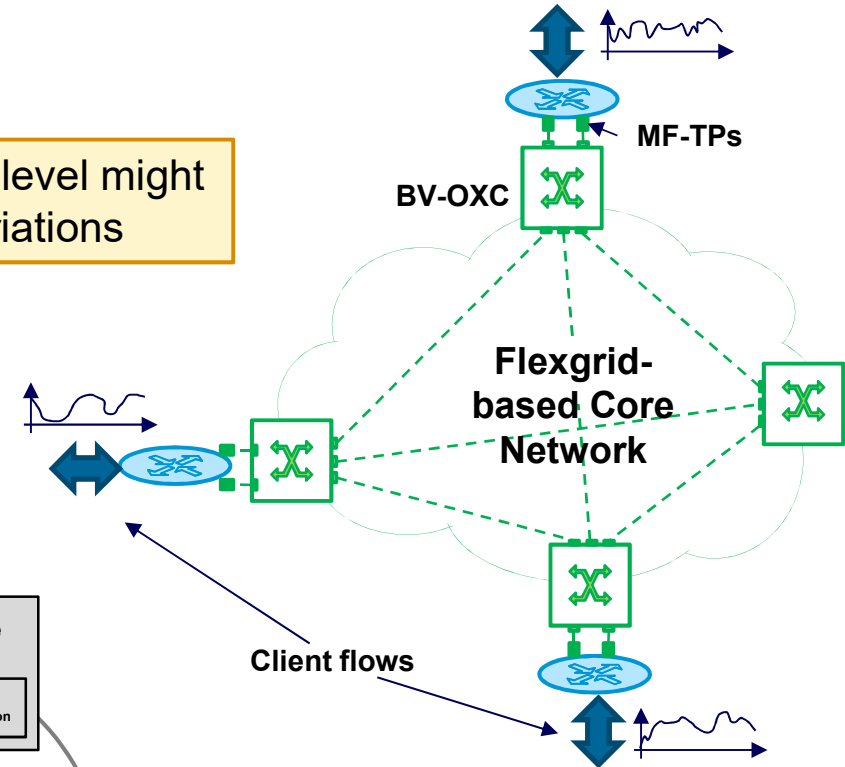
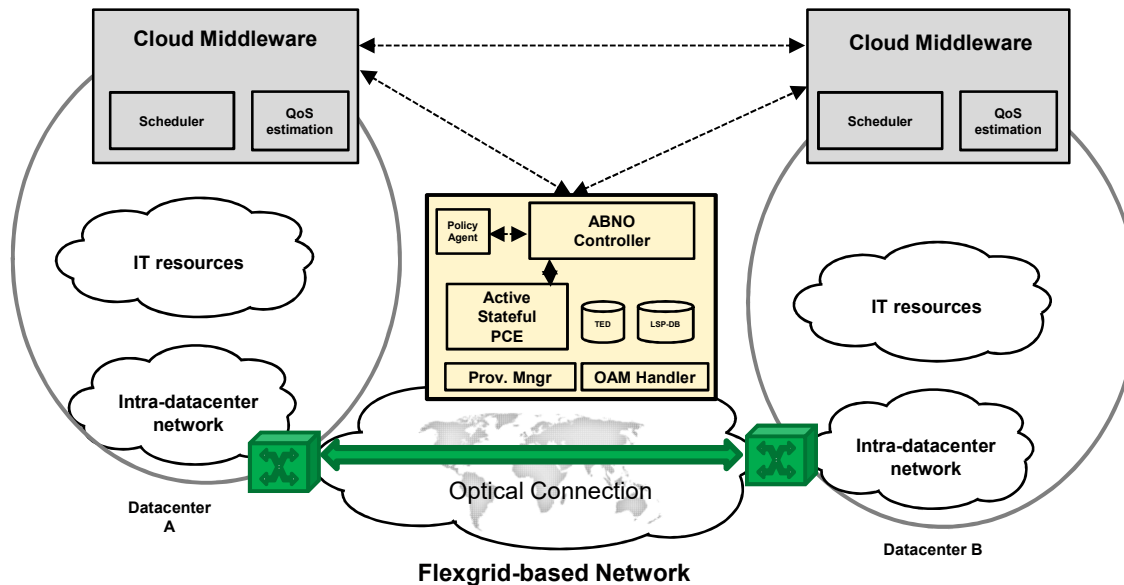

* L. Velasco, et al., "Cross-Stratum Orchestration and Flexgrid Optical Networks for Datacenter Federations," IEEE Network Magazine, vol. 27, pp. 23-30, 2013.

Elastic Spectrum Allocation Policies

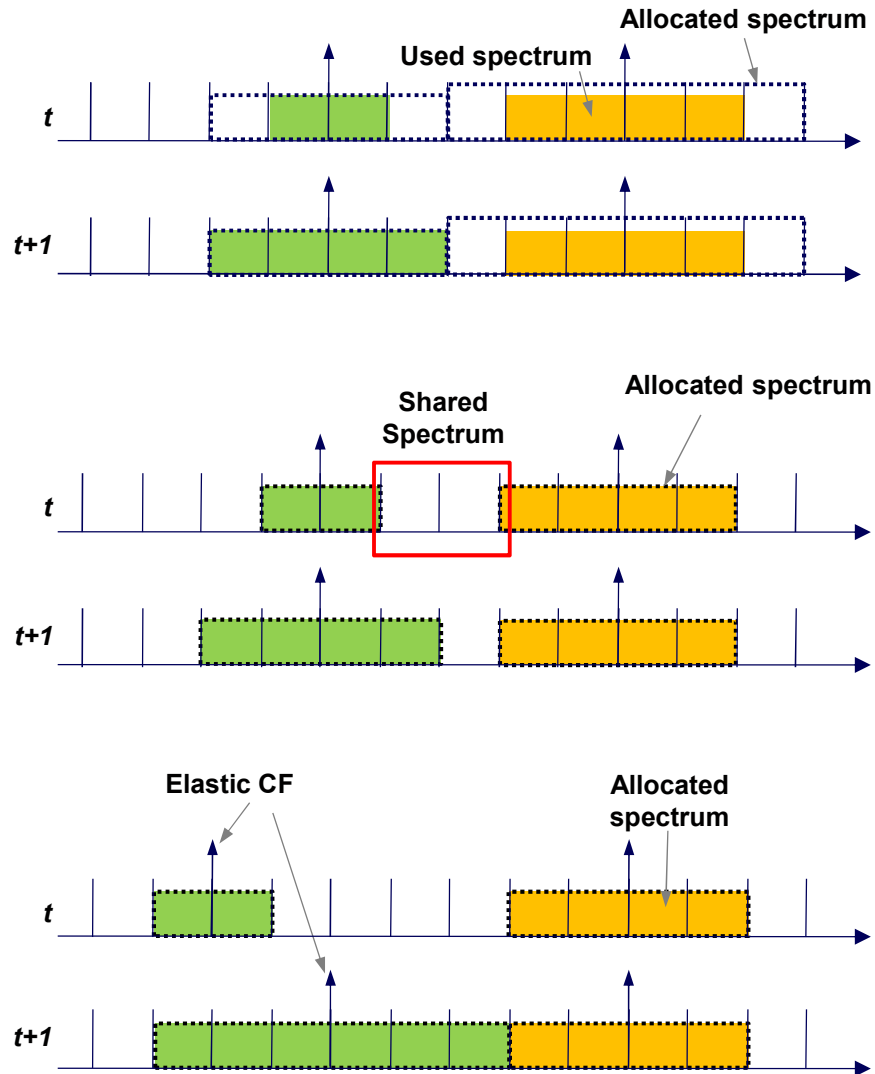

Fixed: both the assigned CF and spectrum width do not change in time.

Semi-Elastic: the assigned CF is fixed but the allocated spectrum may vary.

- At each time interval, the allocated spectrum corresponds to the utilized spectrum.
- Spectrum increments/decrements are achieved by allocating/releasing frequency slices.
- The frequency slices can be shared between neighboring demands, but used by, at most, one demand in a time interval.

Elastic: both the assigned CF and the spectrum width can be subject to change in each time interval.

* M. Klinkowski et al., "Elastic Spectrum Allocation for Time-Varying Traffic in Flexgrid Optical Networks," IEEE Journal on Selected Areas in Communications (JSAC), vol. 31, pp. 26-38, 2013

Example of Re-optimisation (Defragmentation)

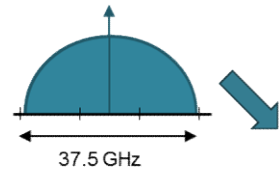

Given:

- an optical network, represented by a graph $G(N, E)$,
- a set S of frequency slots available in each link $e \in E$,
- a set P of already established paths,
- a new path ($newP$) to be established in the network. A route for the path has been already selected but there is no feasible spectrum allocation,
- the threshold num of paths to be reallocated.

Output:

- for each path to be reallocated, its new spectrum allocation,
- the spectrum allocation for $newP$.

Objective: Minimize the amount of paths to be reallocated so to fit $newP$ in.

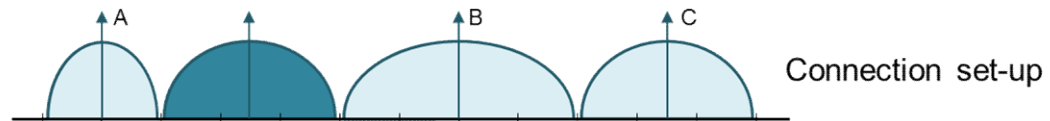
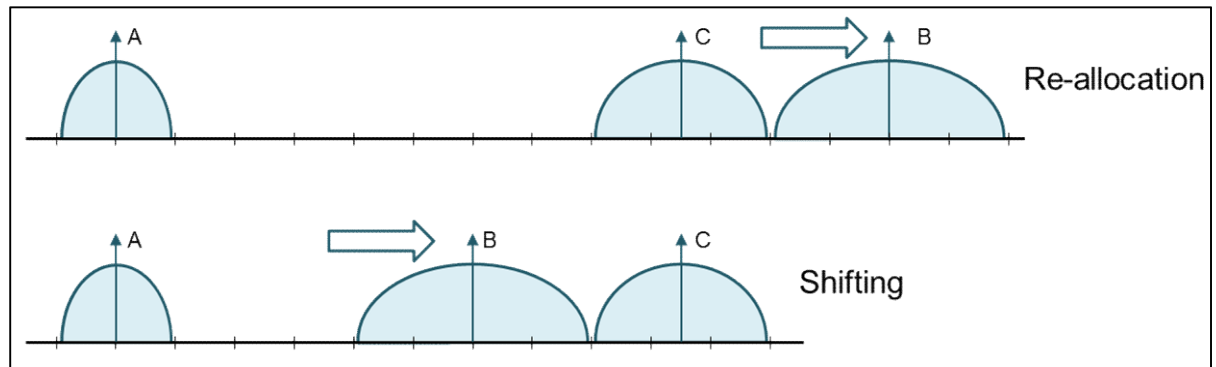
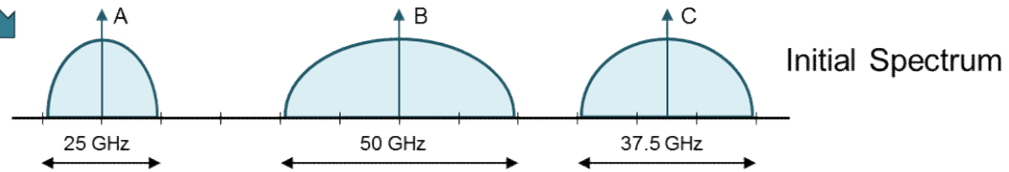

Provisioning-triggered re-optimization

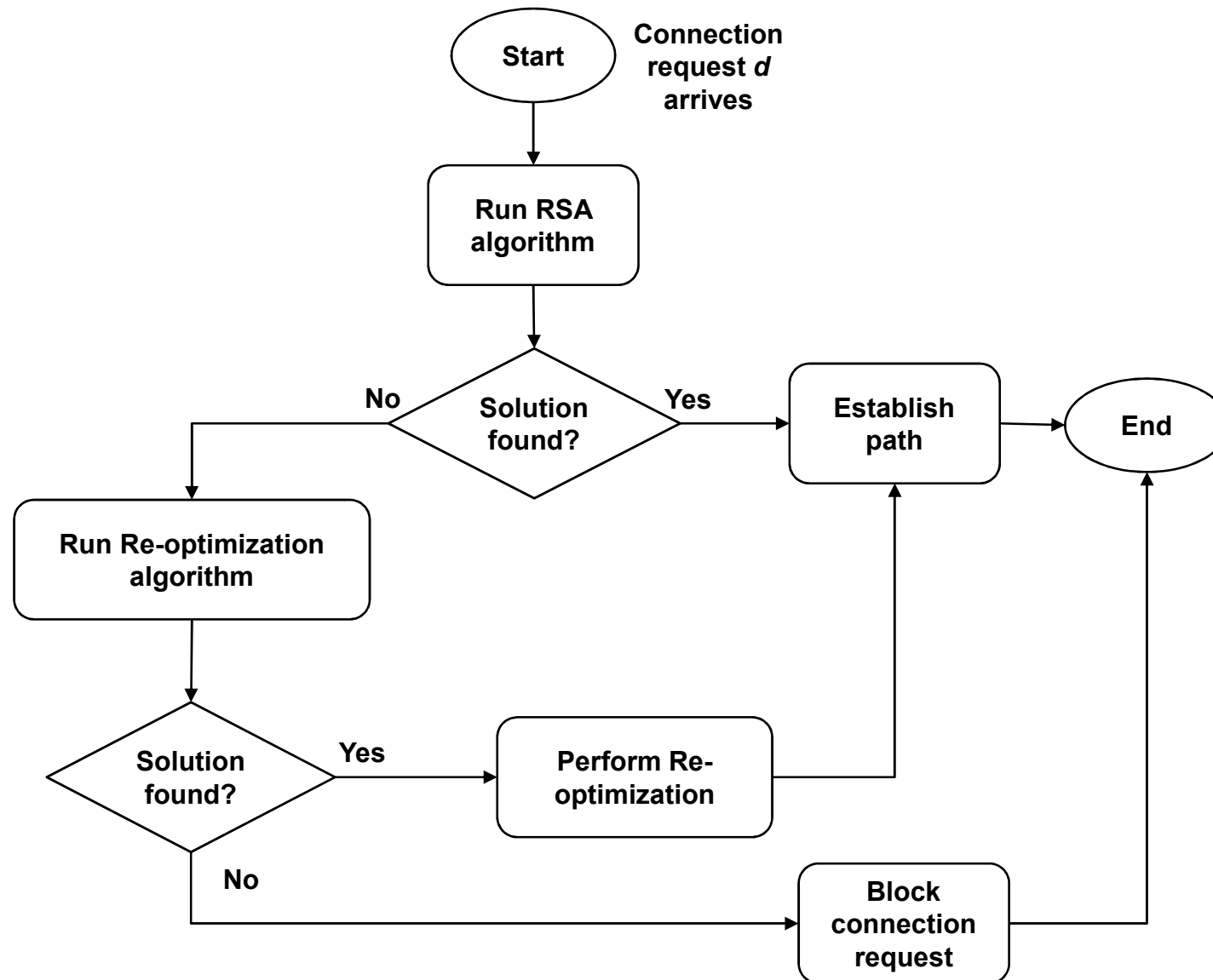

Gains of Defragmentation

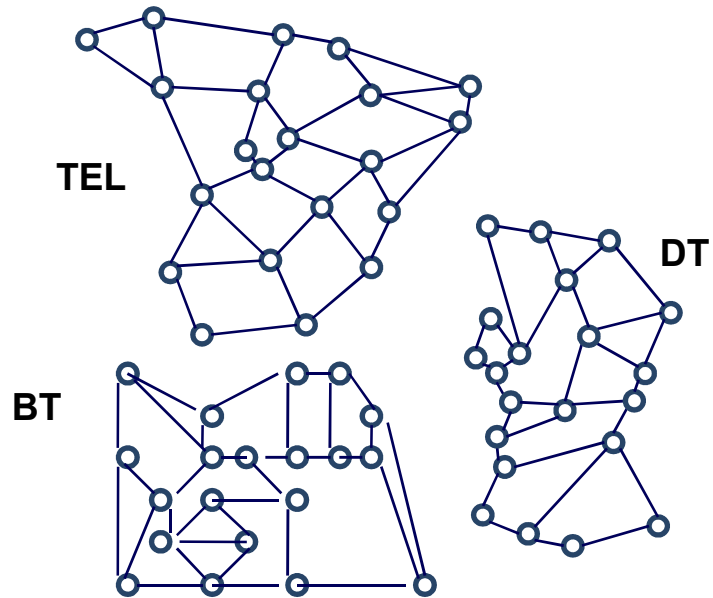

Network	25 GHz	12.5 GHz	6.25 GHz
TEL	30,4%	28,4%	30,3%
BT	22,9%	23,0%	34,1%
DT	22,2%	24,8%	33,0%

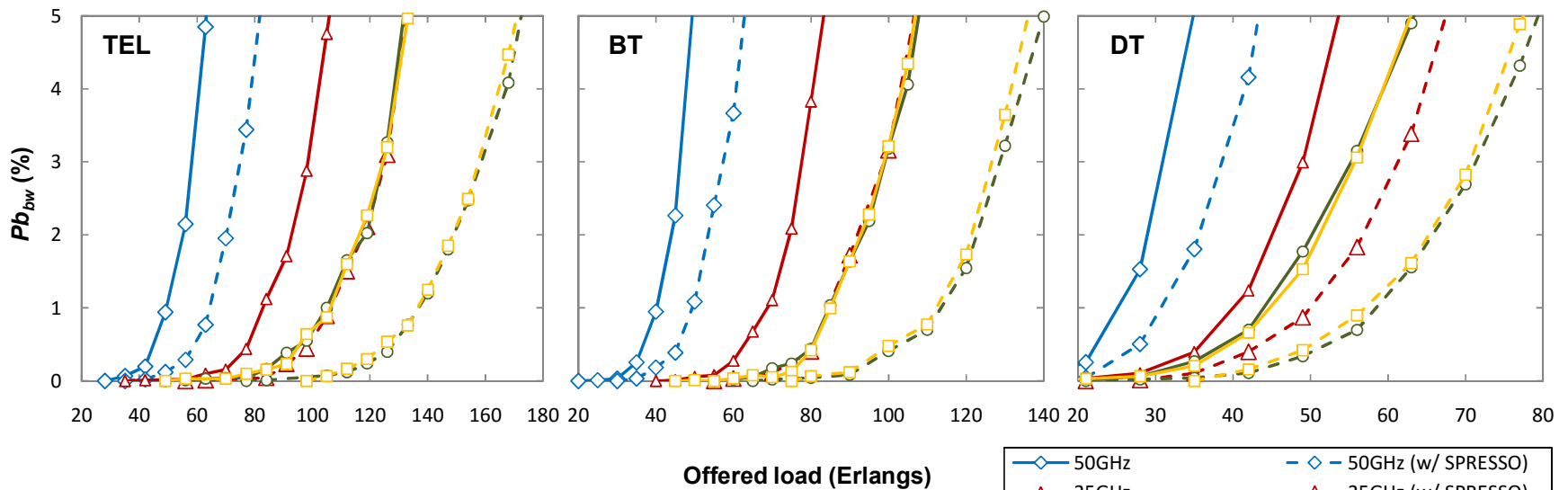

* A. Castro, et al., "Dynamic Routing and Spectrum (Re)Allocation in Future Flexgrid Optical Networks," Elsevier Computers Networks, vol. 56, pp. 2869-2883, 2012.

Example of Re-optimisation (Elasticity)

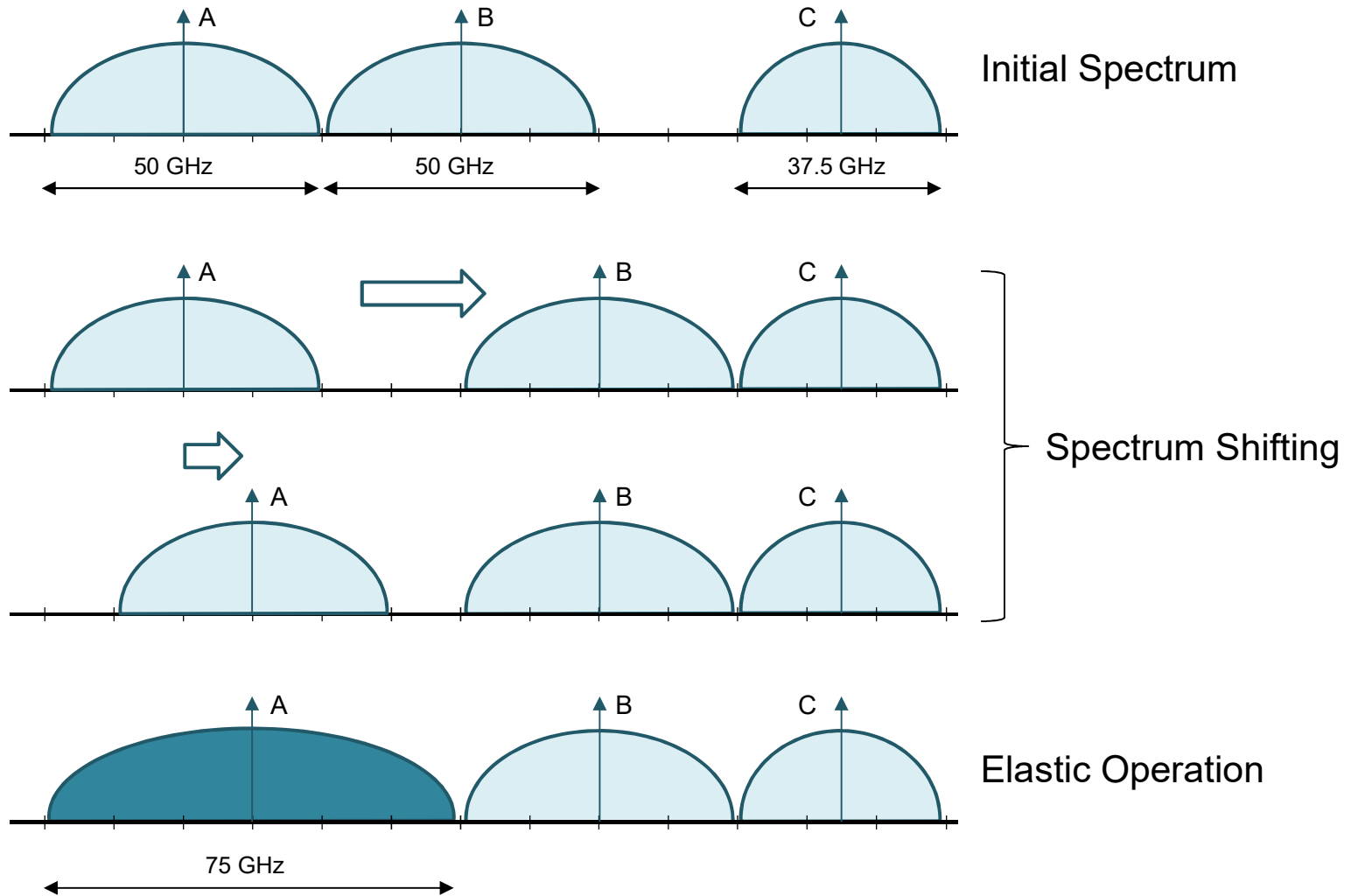

Elastic Operations and Hitless Defragmentation

The EL-SPRESSO problem can be formally stated as:

Given:

- a core network topology represented by a graph $G(N, E)$;
- a set S of available slots of a given spectral width for every link in E ;
- a set L of LSPs already established on the network; each LSP l is defined by the tuple $\{R_l, fc_l, m_l\}$, where the ordered set $R_l \subseteq E$ represents its physical route, fc_l its central frequency and m_l the amount of frequency slots.
- a LSP $p \in L$ for which a request has arrived to increase the SA to number of frequency slots, m_p .

Output: the list of LSPs to be reallocated and the new values for the SA for the given LSP p : $\{R_p, fc_p, m_p\}$.

Objective: minimize the number of reallocations to be performed.

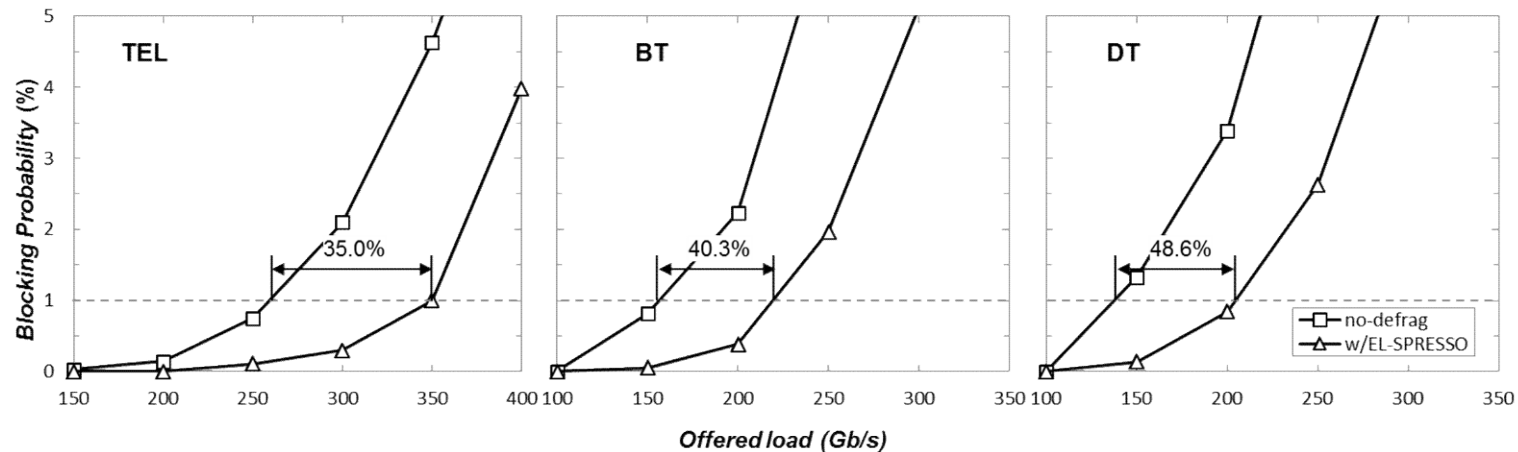

* F. Paolucci et al. "Active PCE Demonstration performing Elastic Operations and Hitless Defragmentation in Flexible Grid Optical Networks," Springer Photonic Network Communications, vol. 29, pp. 57-66, 2015.

LightTrees

Given:

- A network topology represented by a graph $G(V,E)$;
- a set S of available frequency slices of a given spectral width in each link;
- a set of SBVTs installed in every router;
- a set of multicast demands to be served identified by the tuple $\langle s_d, T(d), b_d \rangle$;
- a selected routing scheme (path, tree, or sub-tree).

Output: the RSA for each connection.

Objective: minimize the amount of rejected (blocked) multicast demands (main objective) and the number of used Tx SBVT modules (secondary objective).

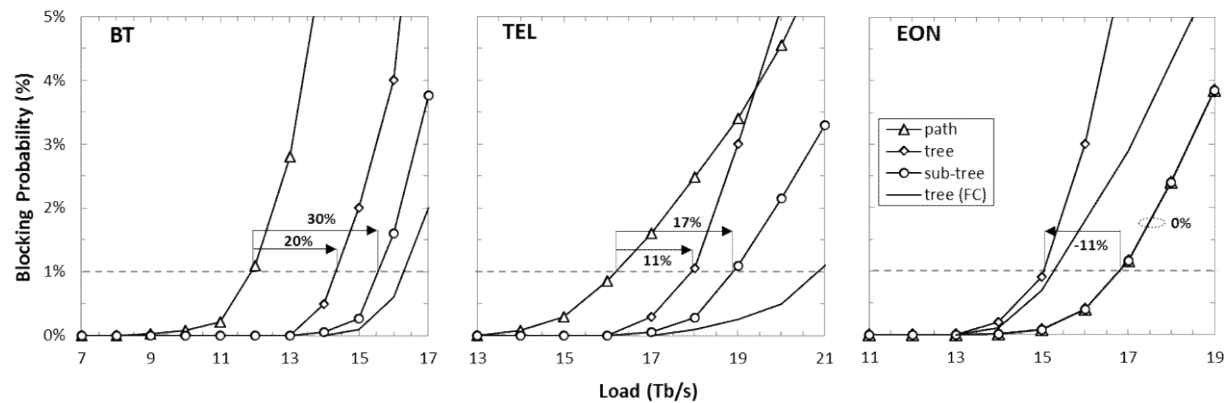
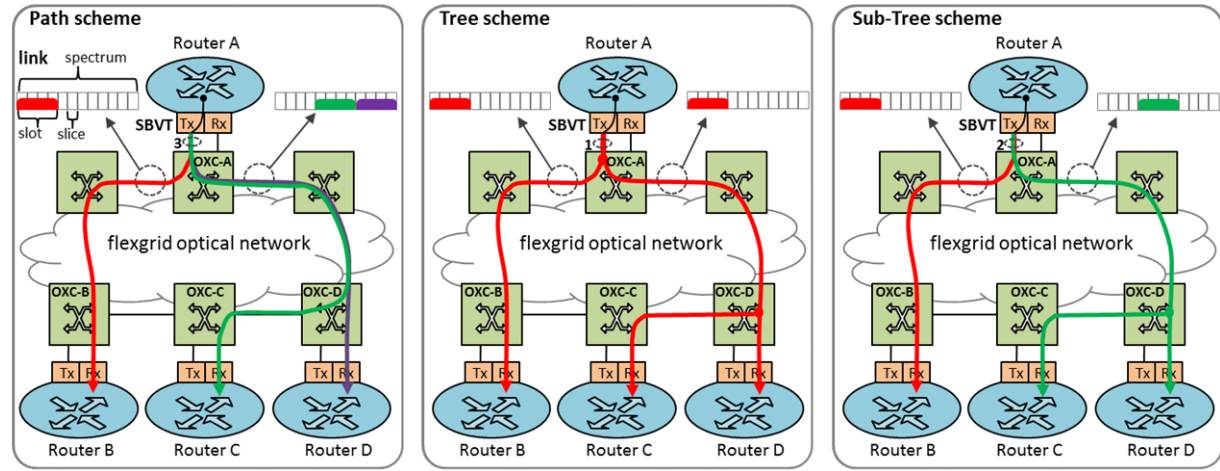

* M. Ruiz and L. Velasco, "Performance Evaluation of Light-tree Schemes in Flexgrid Optical Networks," in IEEE Communications Letters, vol. 18, pp. 1731-1734, 2014.

Multicast connections: Optical vs Multilayer

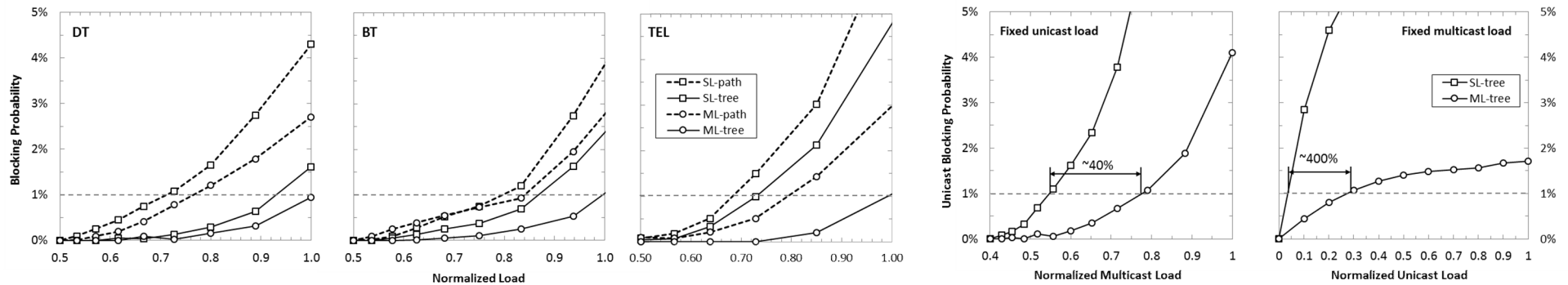
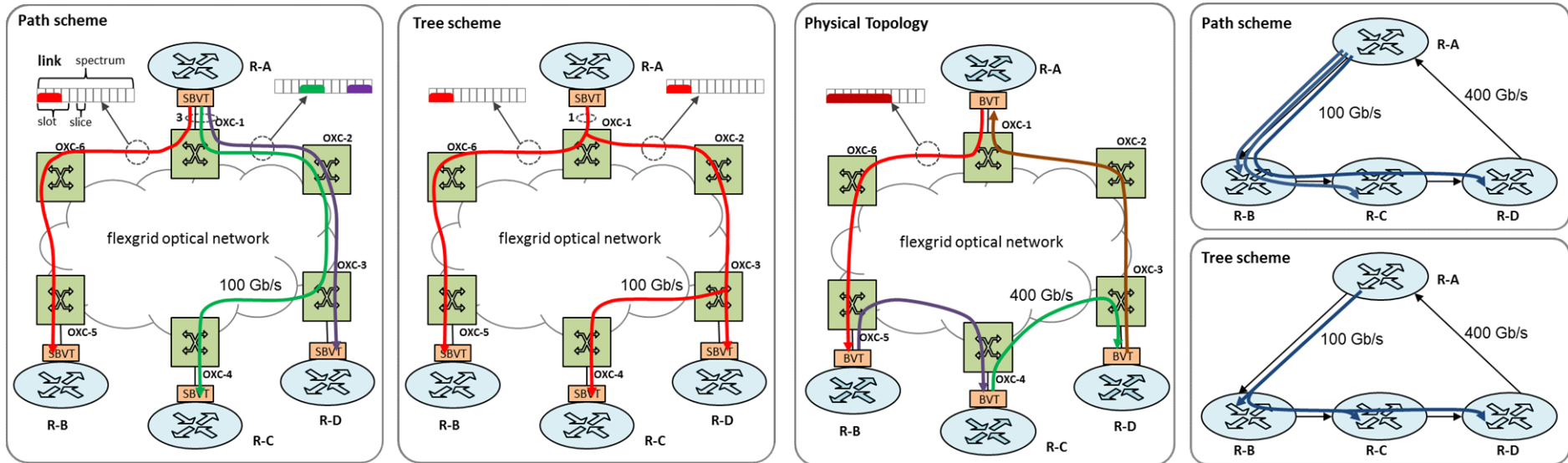

* M. Ruiz and L. Velasco, "Serving Multicast Requests on Single Layer and Multilayer Flexgrid Networks," IEEE/OSA Journal of Optical Communications and Networking (JOCN), vol. 7, pp. 146-155, 2015.

Bulk path computation

- Path computation for a set of connection requests.
 - the bulk of path requests is computed attaining the optimal solution for the whole set.
 - Increases optimality but increases also provisioning time.
- Bulk path computation can be used for restoration.
 - Reduces resource contention.
 - Increases resource utilization, specially in MLN.
 - Stringent computation times require heuristic algorithms.

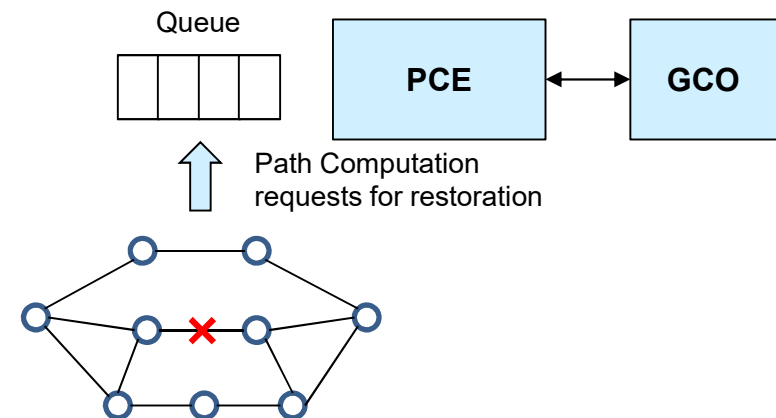

* A. Castro et al., "Experimental Assessment of Bulk Path Restoration in Multi-layer Networks using PCE-based Global Concurrent Optimization," IEEE/OSA Journal of Lightwave Technology (JLT), vol. 32, pp. 81-90, 2014

Bitrate Squeezed and Multi-path Recovery

Path Recovery	Description
Protection	Protection routes are known in advance: <ul style="list-style-type: none"> • Dedicated Protection • Shared Protection
Restoration	Restoration routes are found adaptively based on the failure and the state of the network at the time of failure.

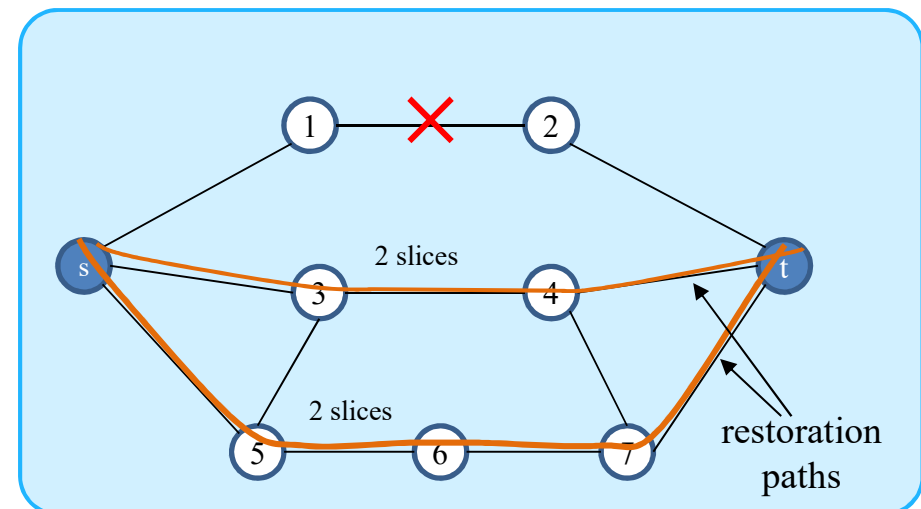
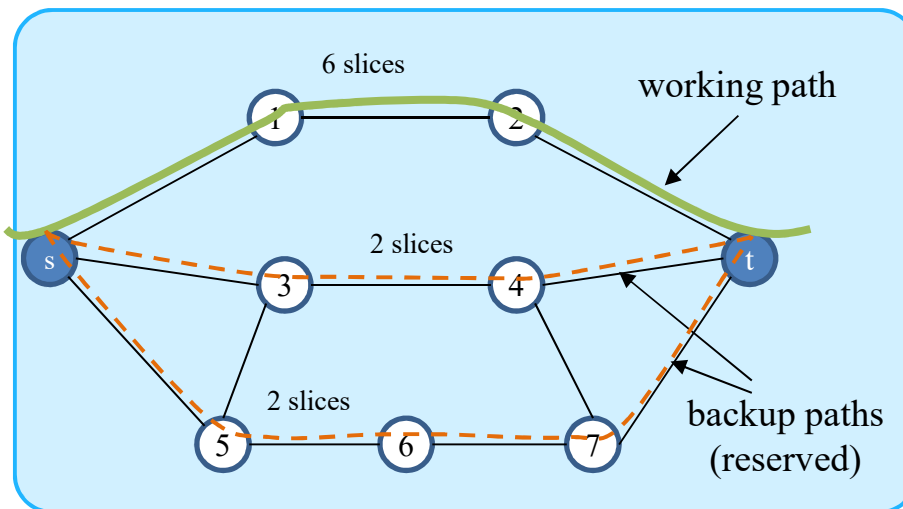

* A. Castro et al., "On the benefits of Multi-path Recovery in Flexgrid Optical Networks," Springer Photonic Network Communications, vol. 28, pp. 251-263, 2014.

After Failure Repair Re-optimization (AFRO)

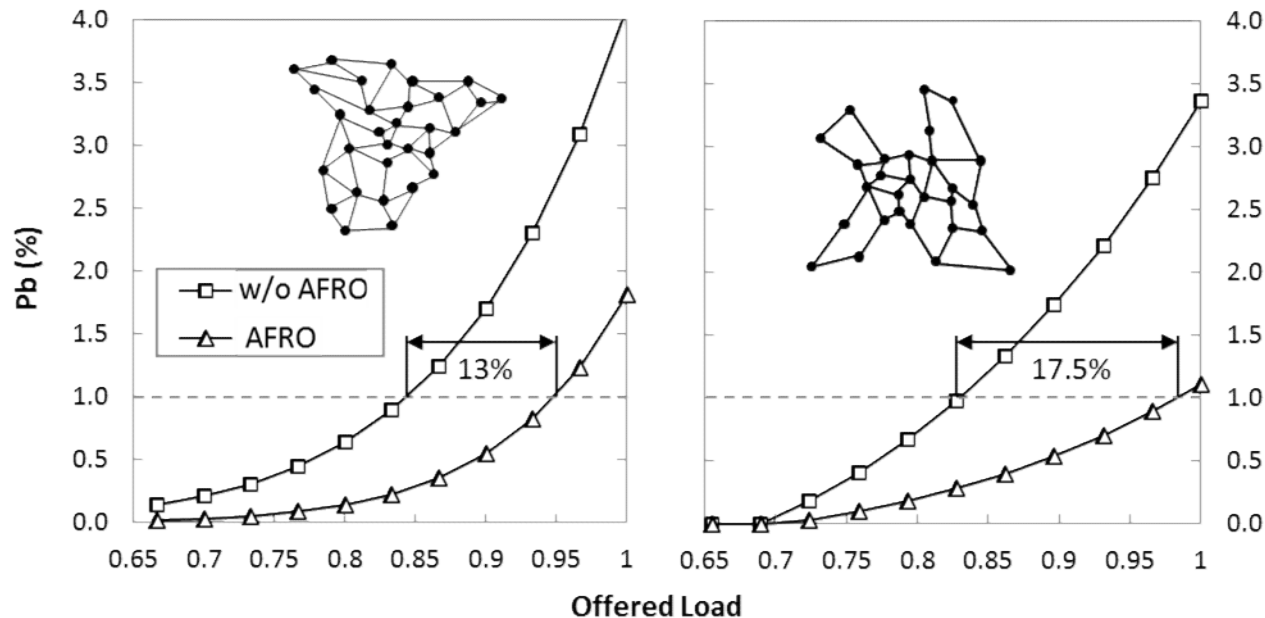
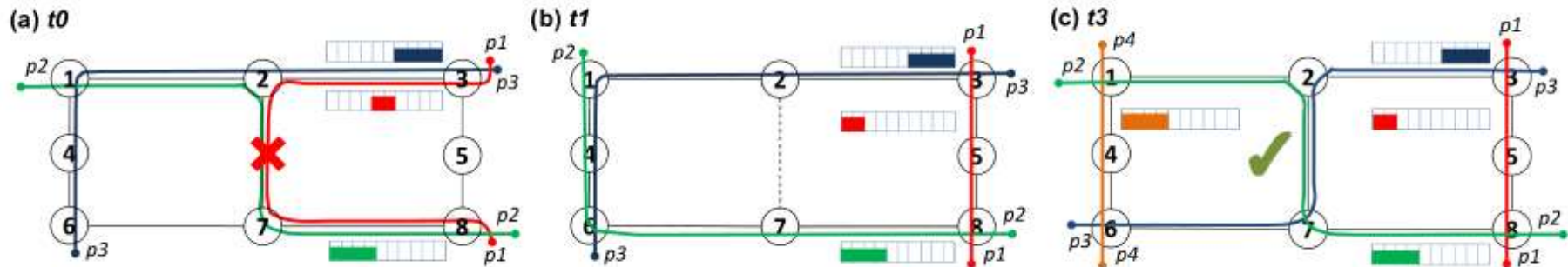

* M. Zotkiewicz et al., "Reoptimization of Dynamic Flexgrid Optical Networks After Link Failure Repairs," IEEE/OSA Journal of Optical Comm and Networking (JOCN), vol. 7, pp. 49-61, 2015.

* Ll. Gifre et al., "First Experimental Assessment of ABNO-driven In-Operation Flexgrid Network Re-Optimization," IEEE/OSA Journal of Lightwave Technology (JLT), vol. 33, pp. 618-624, 2015.

Modulation Format-aware Restoration and Re-optimization

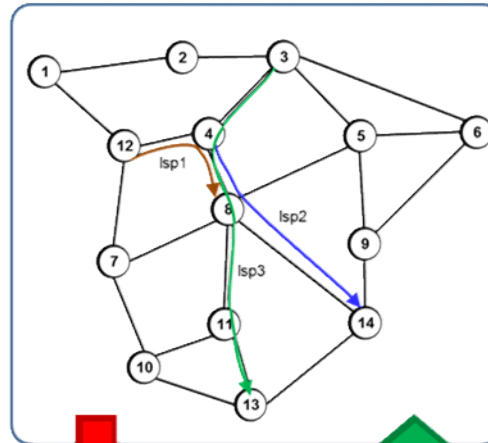
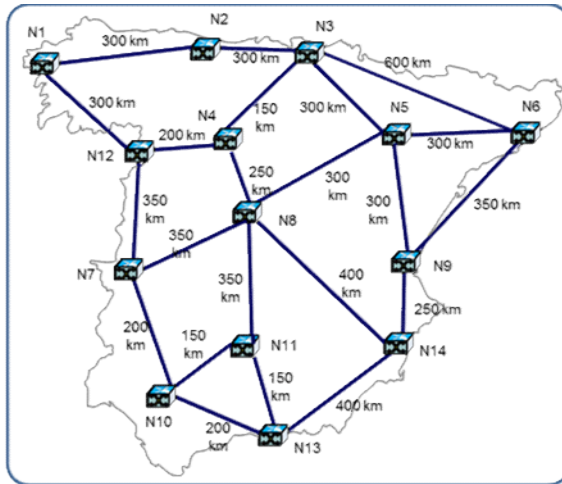

Before Failure				
LSP	BitRate (Gb/s)	Length (km)	Mod. Format	Slot Width (GHz)
lsp1	200	450	DP-QAM16	25
lsp2	400	650	DP-QAM16	50
lsp3	300	900	DP-QAM8	50

Mod. Format	Spectral Efficiency (bit/symbol)	Reach (km)
DP-QPSK	4	3000
DP-QAM8	6	1000
DP-QAM16	8	650

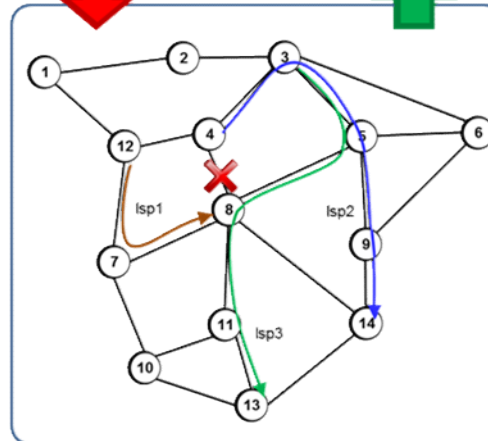

After Restoration				
LSP	BitRate (Gb/s)	Length (km)	Mod. Format	Slot Width (GHz)
lsp1	200	700	DP-QPSK	50
lsp2	300	1000	DP-QAM8	50
lsp3	100	1100	DP-QPSK	25

* LI. Gifre et al. "Modulation Format-aware Re-Optimization in Flexgrid Optical Networks: Concept and Experimental Assessment," in Proc. ECOC, 2015.

SBVTs under dynamic traffic

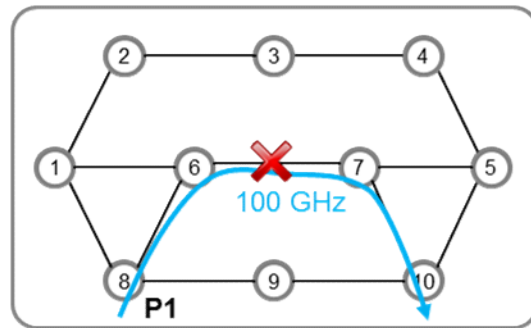

Restoration

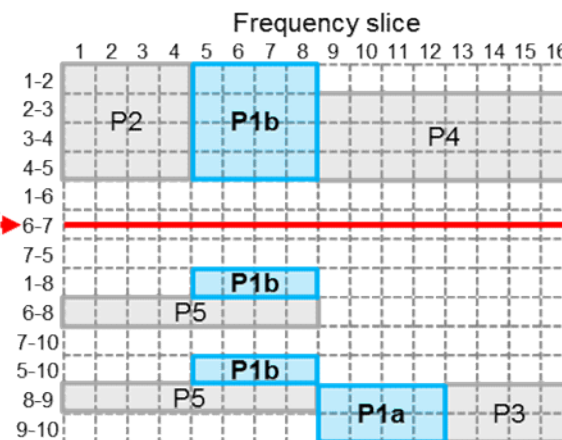
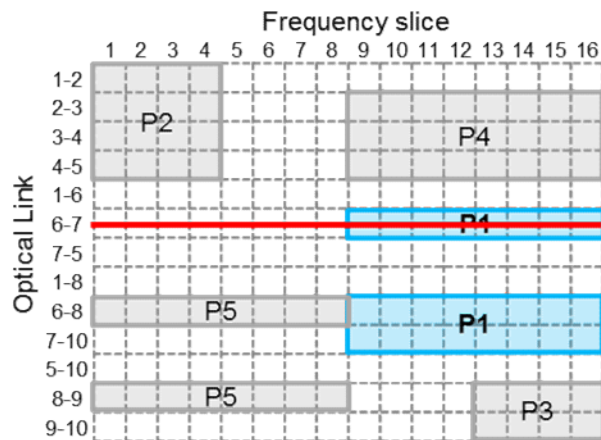
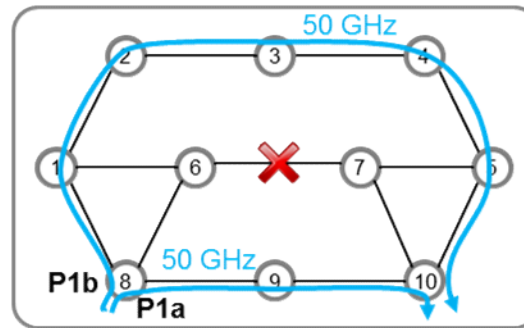

Mod. Format	bits/symbol	Reach
DP-QPSK	4	3000 Km
DP-QAM8	6	1000 Km
DP-QAM16	8	650 Km

Path Id	Bitrate (Gb/s)	Len. (Km)	Mod. Format	Slot Width
P1	400	550	DP-QAM16	100 GHz
P1a	200	300	DP-QAM16	50 GHz
P1b	100	1250	DP-QPSK	50 GHz

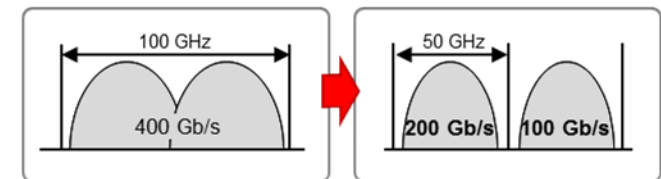

Routing and Scheduled Spectrum Allocation (RSSA)

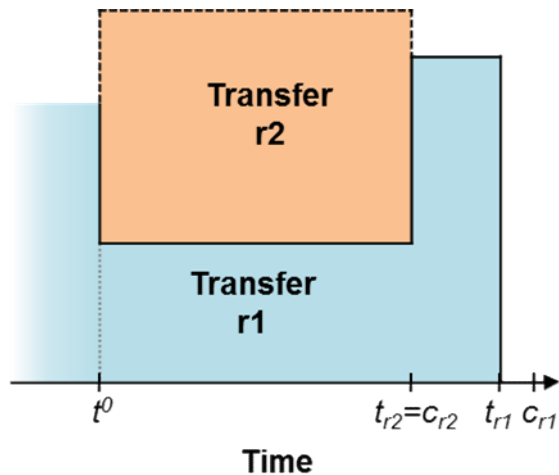
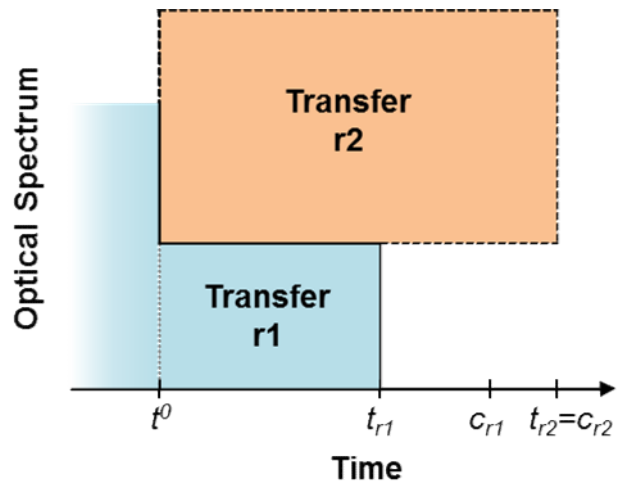

Given:

- a network topology represented by a graph $G(L, E)$, being L the set of locations and E the set of fiber links connecting two locations;
- a subset $D \subseteq L$ with those locations source of transfer-mode traffic (datacenters);
- a subset $U \subseteq L$ with those locations source of fixed-bitrate traffic;
- the characteristics of the spectrum for each link in E : a set S of available spectrum slices of a given spectrum width;
- the characteristics (capacity and number of flows) of the optical transponders equipped in each location;
- a set R with the transferences currently in progress in the network. For each transference $r \in R$, the tuple $\{o_r, d_r, v_r, c_r, r_r, s_r^0, s_r^l, t_r^l, t_r\}$ specifies the origin (o_r) and destination (d_r) datacenters, the remaining amount of data (v_r) to be transferred, the requested completion time (c_r), the route (r_r) and slot currently allocated (s_r^0), the scheduled slot allocation (s_r^l) to be performed at time t_r^l , and the scheduled completion time (t_r);
- the new transfer-mode request, described by the tuple $\{o_r, d_r, v_r, c_r\}$. Let t^0 denote the current time.

Output:

- the route (r_r), the slot allocation (s_r^0) and the scheduled completion time (t_r) for the new transference request. The bitrate of the connection is given by $b(s_r^0, l(r_r))$, where $l(r_r)$ returns the total length of the route r_r .
- the new spectrum allocation (w_r^0), scheduled reallocation (w_r^l, t_r^l) and completion time (t_r) for each transference request to be re-scheduled.

Objective: Minimize the number of connections to be re-scheduled to make room for the incoming request.

* A. Asensio and L. Velasco, "Managing Transfer-based Datacenter Connections," IEEE/OSA Journal of Optical Communications and Networking (JOCN), vol. 6, pp. 660-669, 2014.

Results

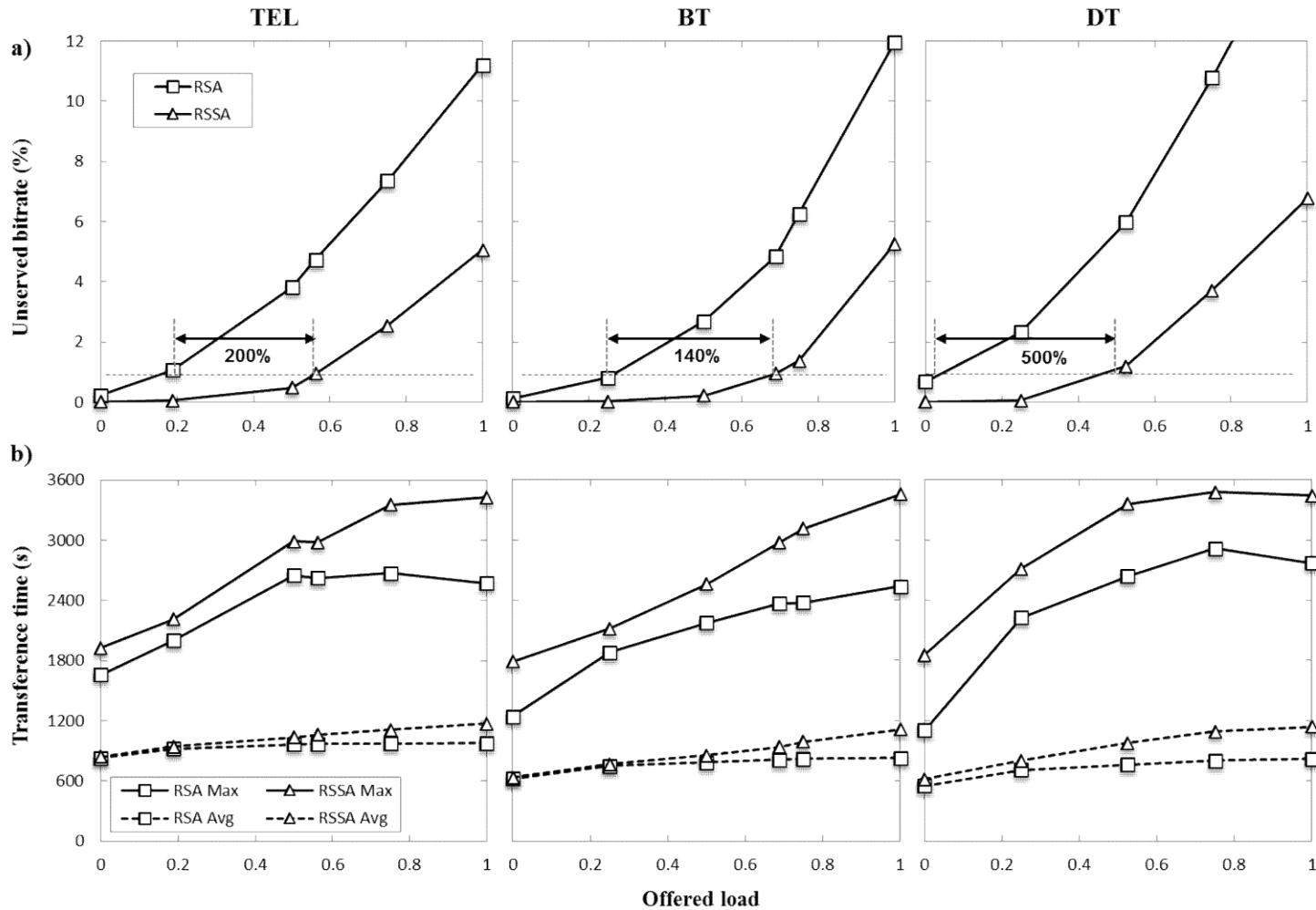

CVN Provisioning with QoS Constraints and Bitrate Guarantees

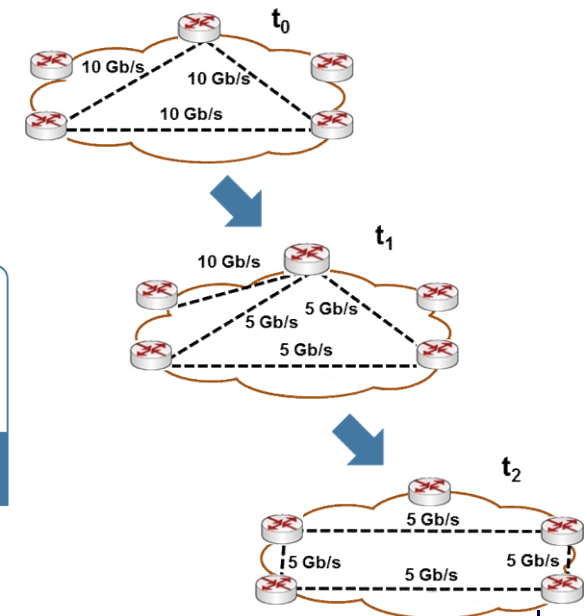
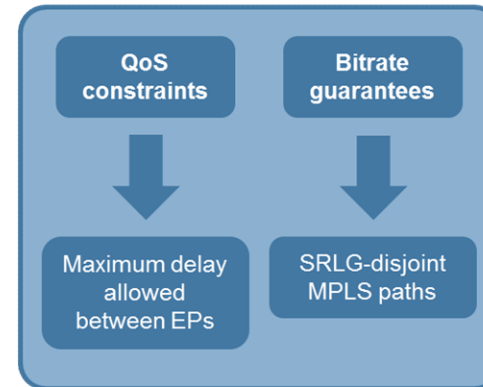
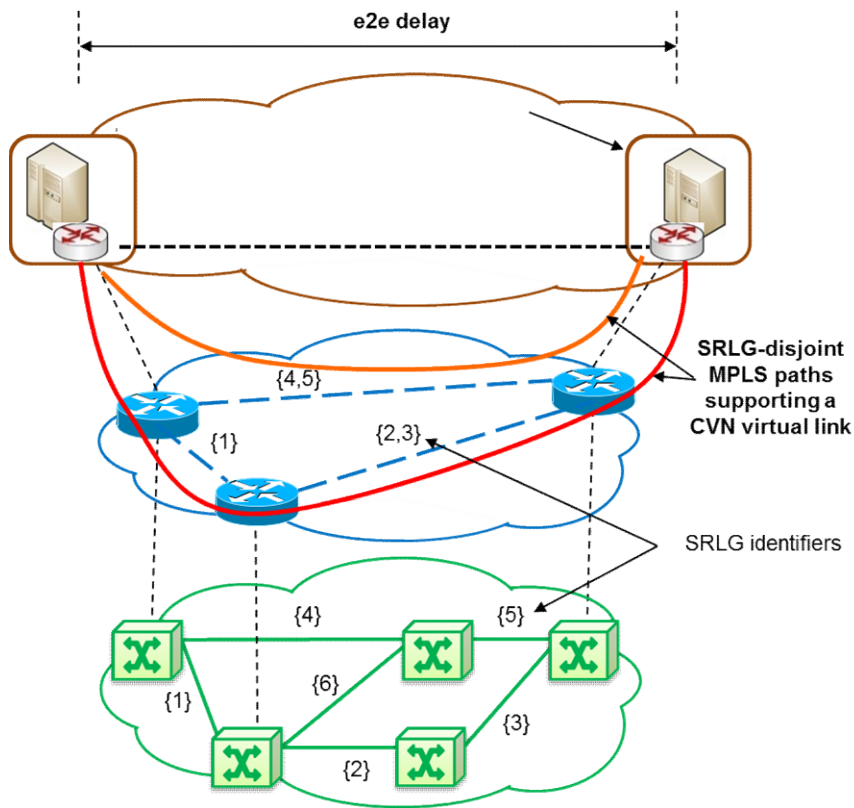

Gb/s	EP1	EP2	EP3
EP1	-	0	60
EP2	0	-	80
EP3	60	80	-

Capacity matrix

ms	EP1	EP2	EP3
EP1	-	0	10
EP2	0	-	10
EP3	10	10	-

Quality of Service (QoS)

Gb/s	EP1	EP2	EP3
EP1	-	0	30
EP2	0	-	40
EP3	30	40	-

Bitrate guarantees



UNIVERSITAT POLITÈCNICA
DE CATALUNYA

Optical
Communications
Group



Part IV

Extending networks life-cycle

Luis Velasco

Static Network Operation

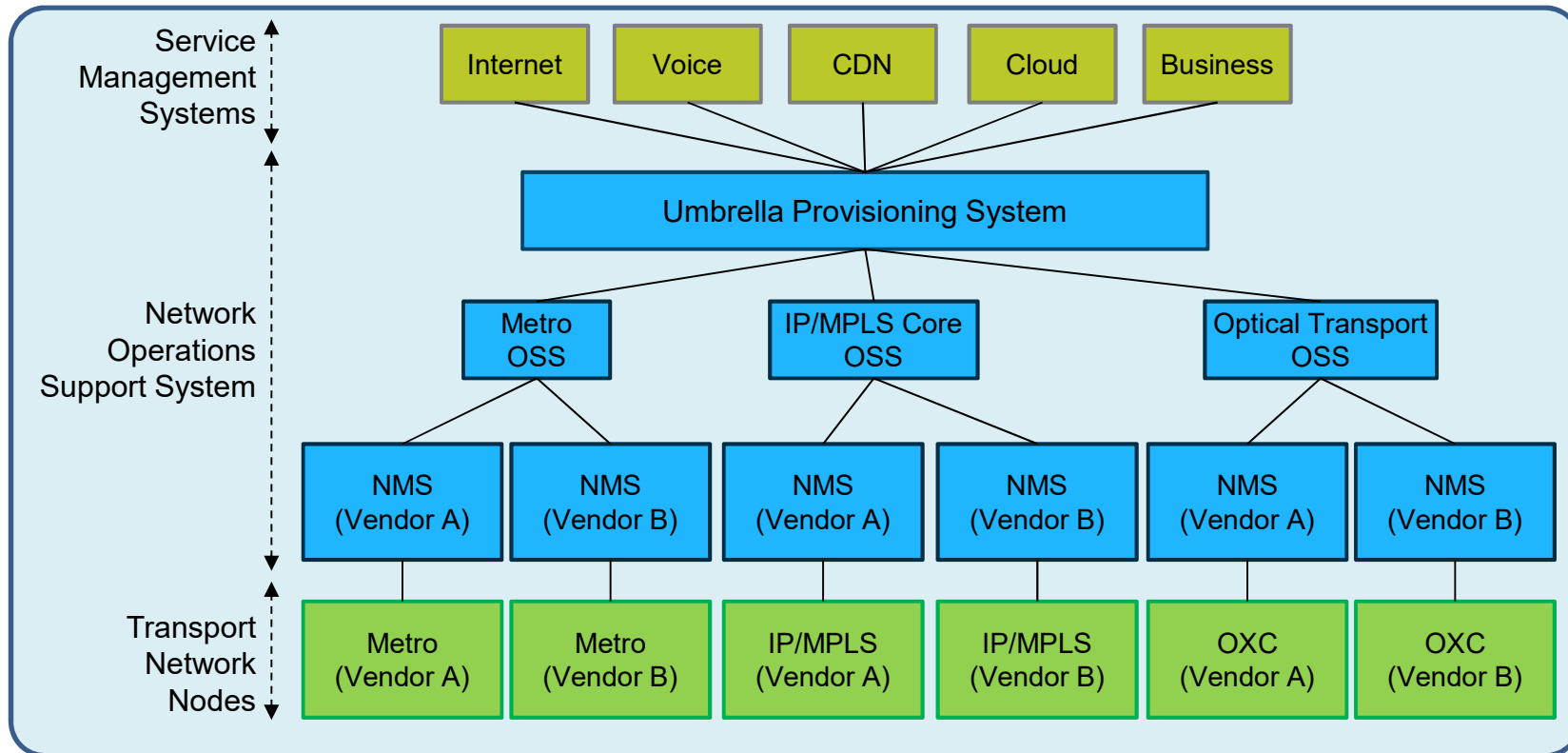

Migration towards in-operation network planning

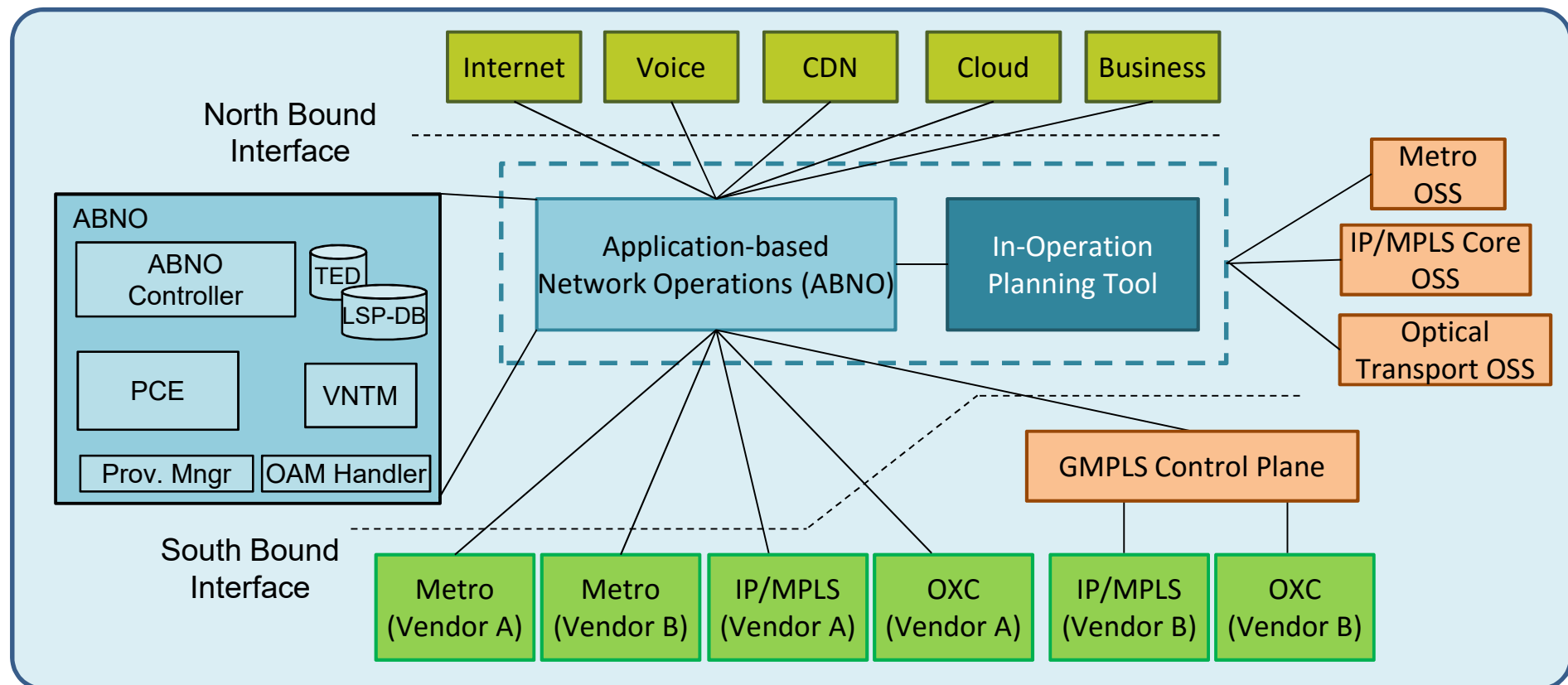

Re-optimisation Process

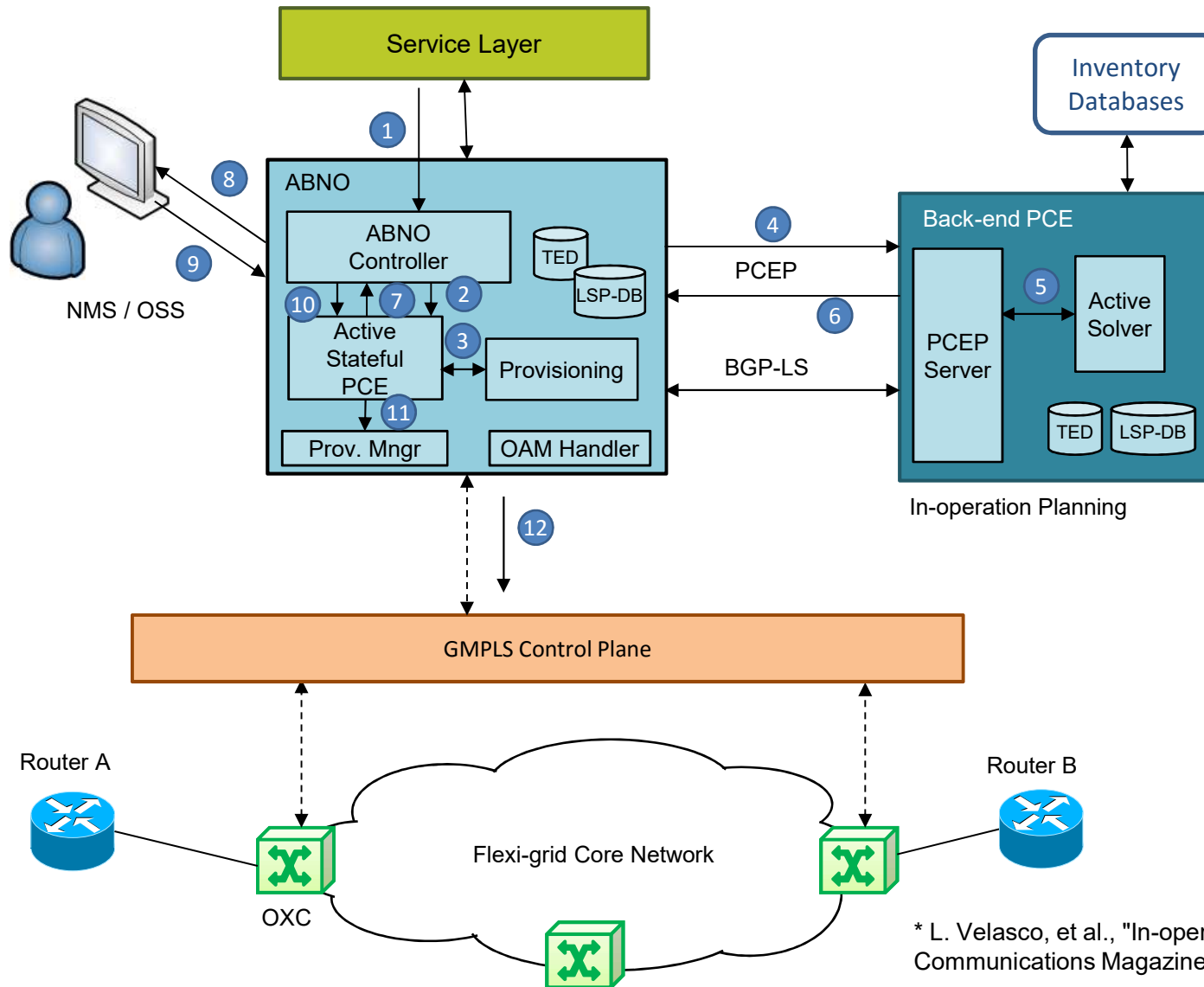

* L. Velasco, et al., "In-operation Network Planning," IEEE Communications Magazine, vol. 52, pp. 52-60, 2014.

In-operation Planning

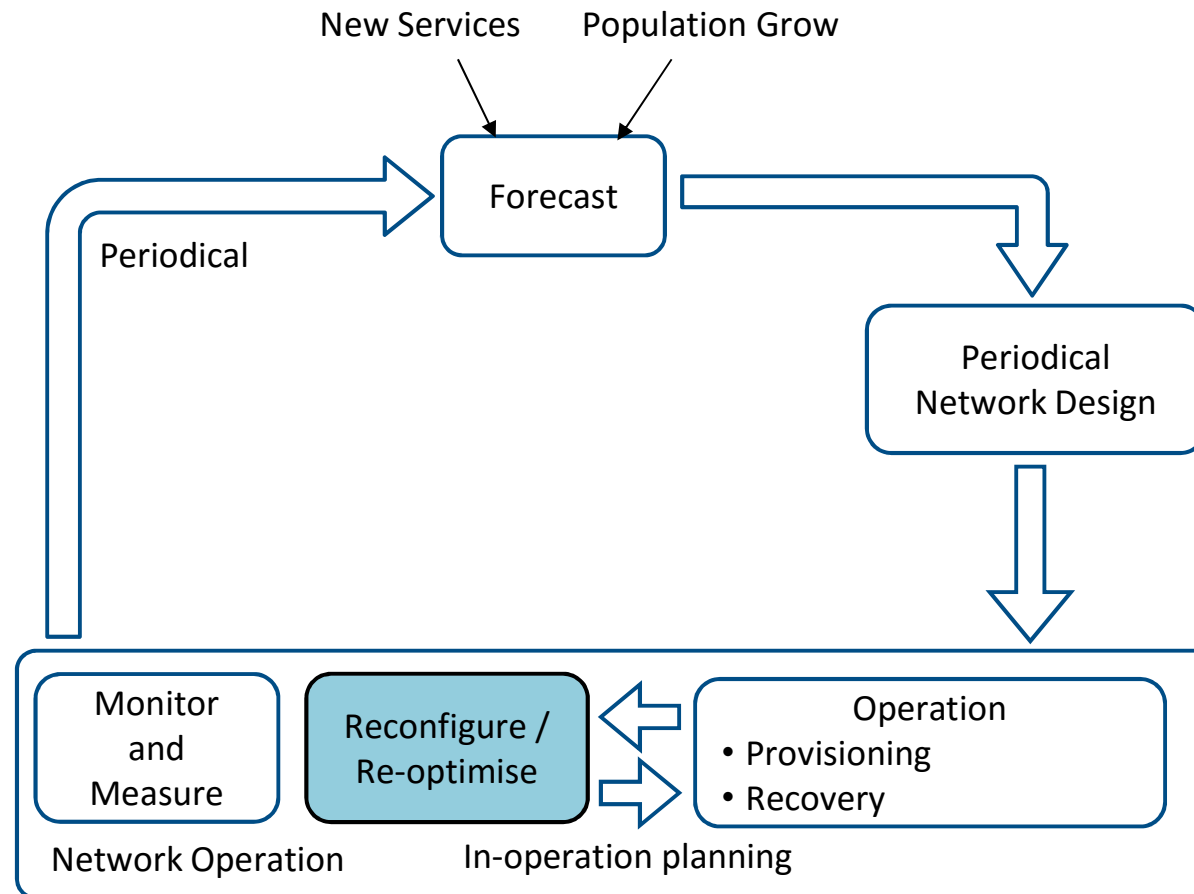

Incremental Planning

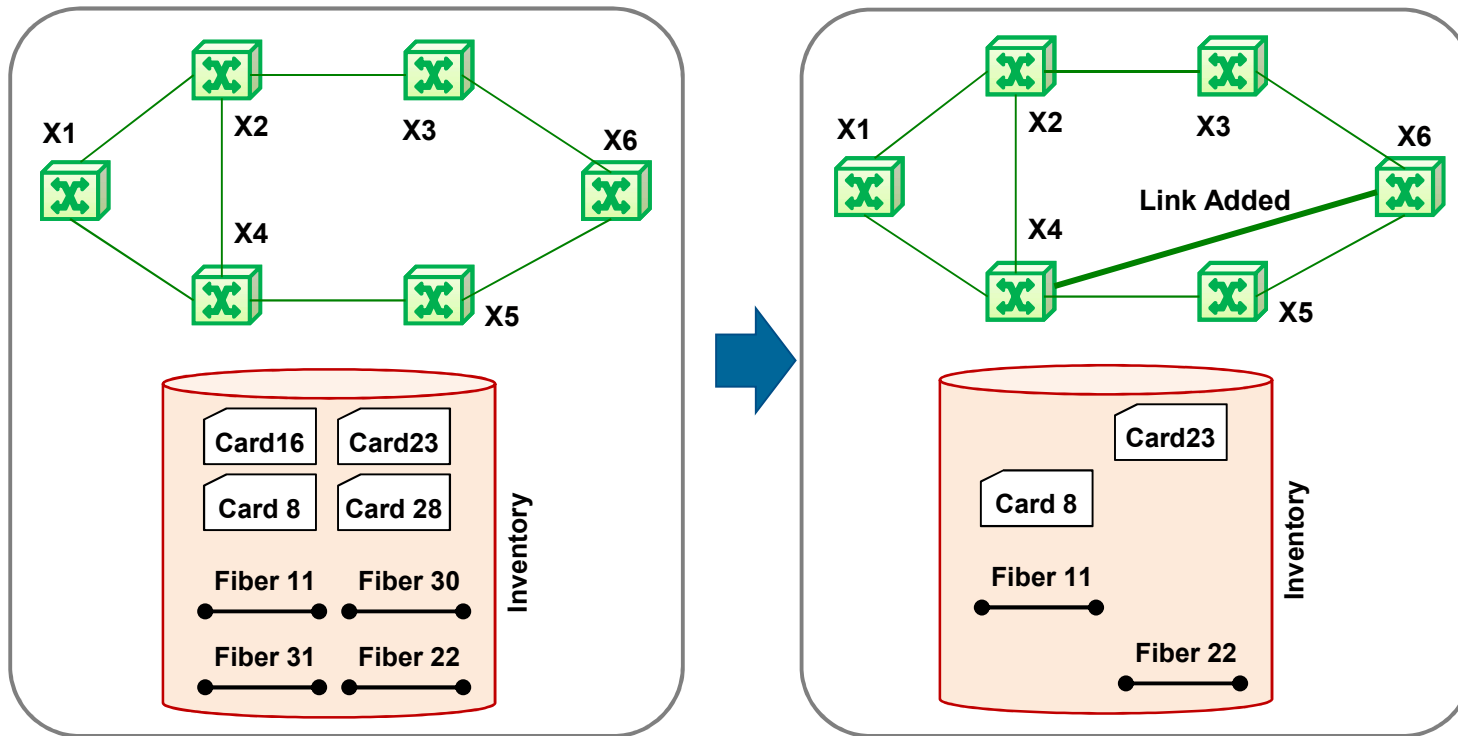

Results

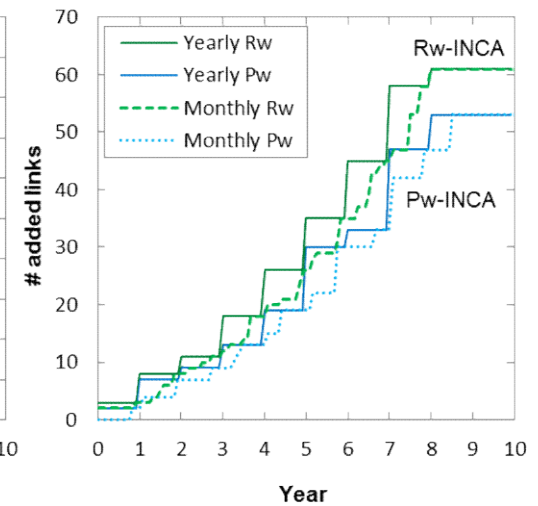
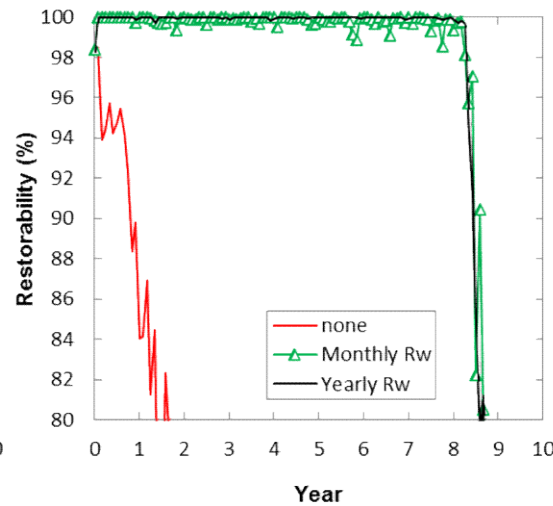
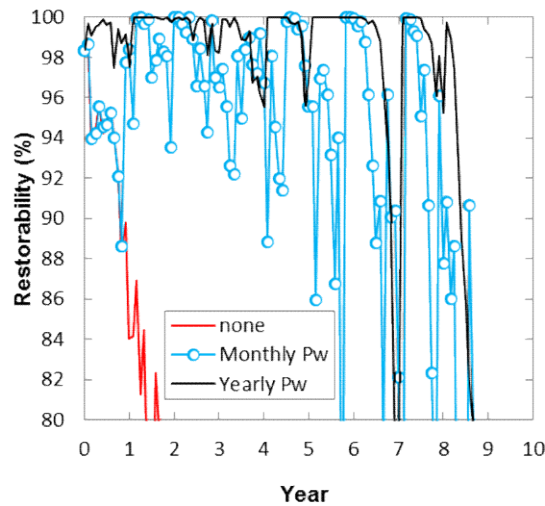
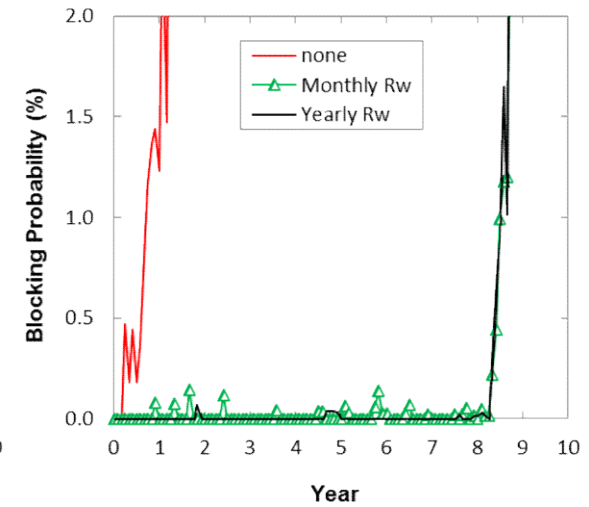
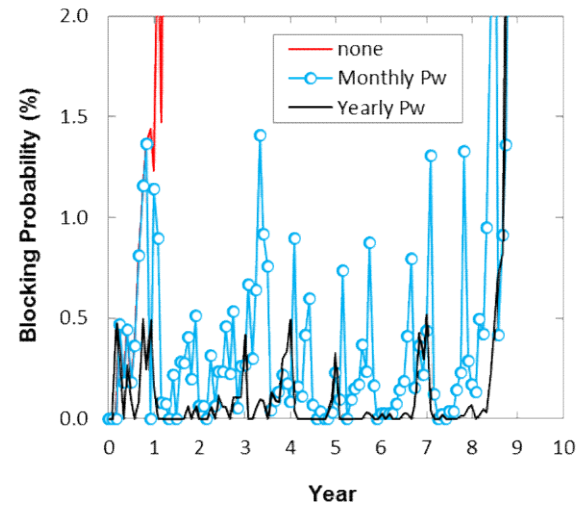

Extended Networks Life Cycle

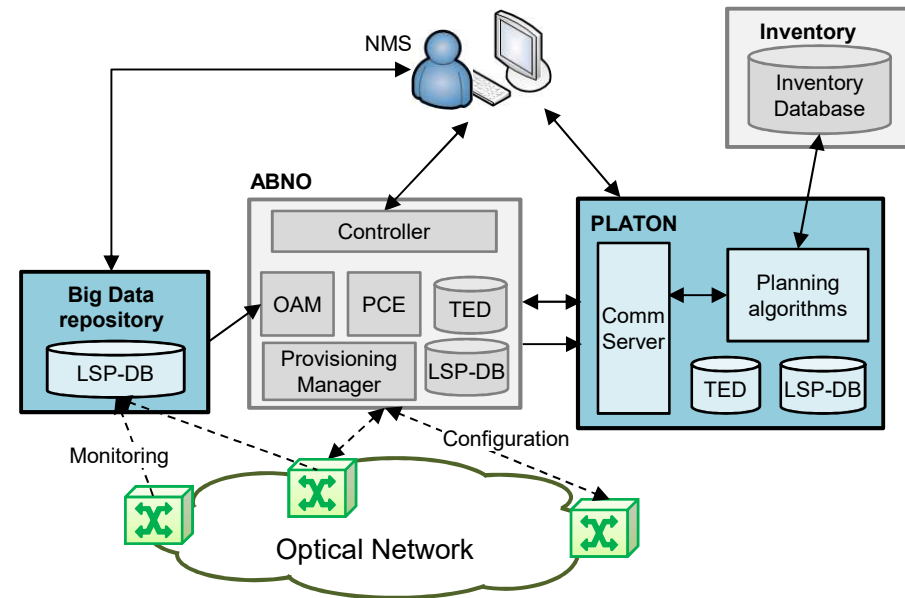
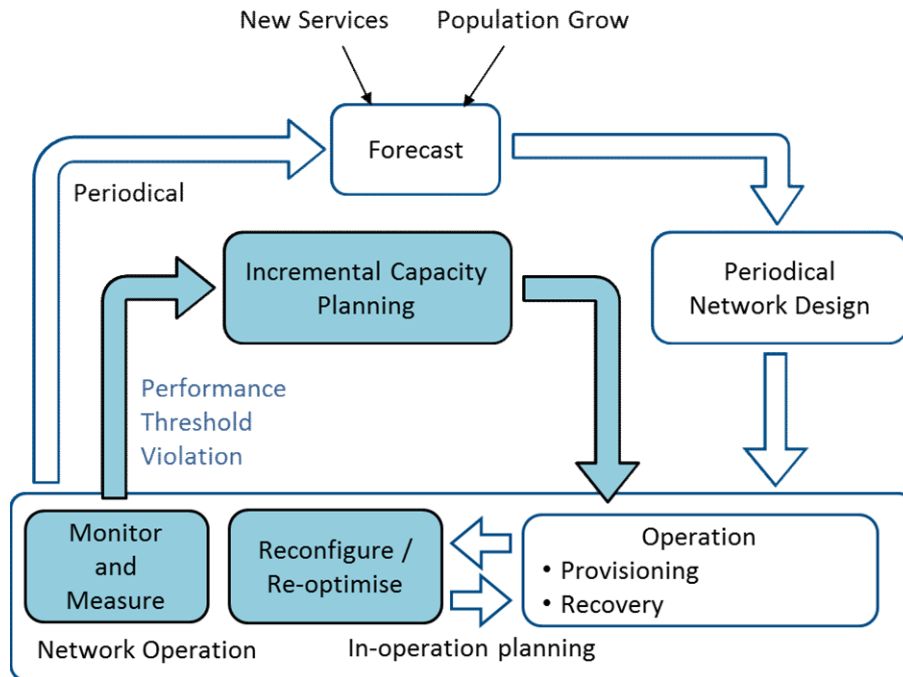

* L. Velasco et al., "On-demand Incremental Capacity Planning in Optical Transport Networks," IEEE/OSA Journal of Optical Communications and Networking (JOCN), vol. 8, pp. 11-22, 2016.



UNIVERSITAT POLITÈCNICA
DE CATALUNYA

Optical
Communications
Group



Part V

Towards Cognitive Networking

Luis Velasco

Source-destination traffic analysis

- Data collected from packet nodes
 - Every L2/L3 node generates a sample of monitored data every fixed time interval (e.g. 5 min)
 - Sample = traffic sent from this source to every destination
- Huge amount of monitored data samples
 - Pre-processing and modelling is necessary
 - Data stream mining -> Sketches
 - ML and Statistics -> Models
- Applications for network optimization
 - Traffic prediction-based in-operation planning
 - Model-triggered network re-optimization

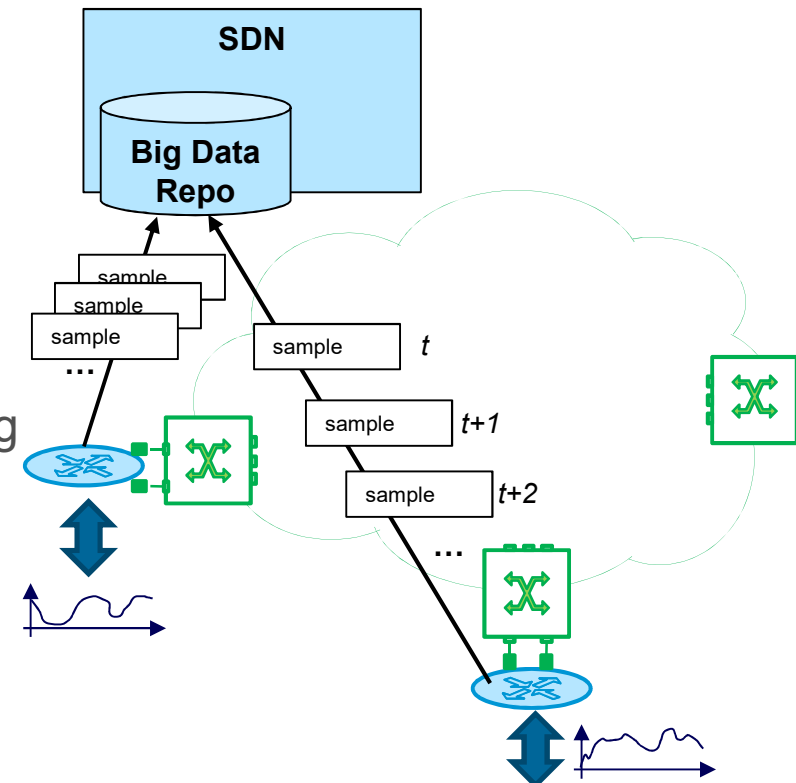

VNT reconfiguration

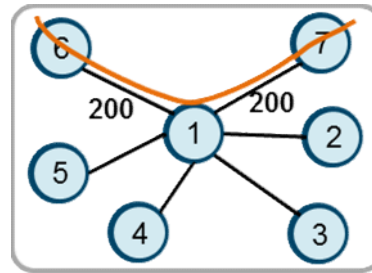
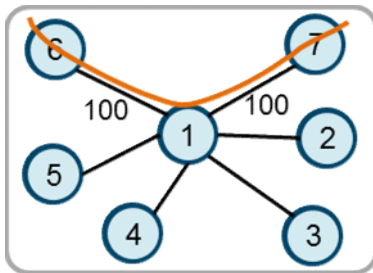
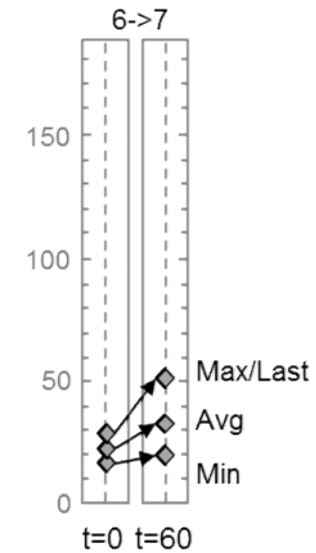
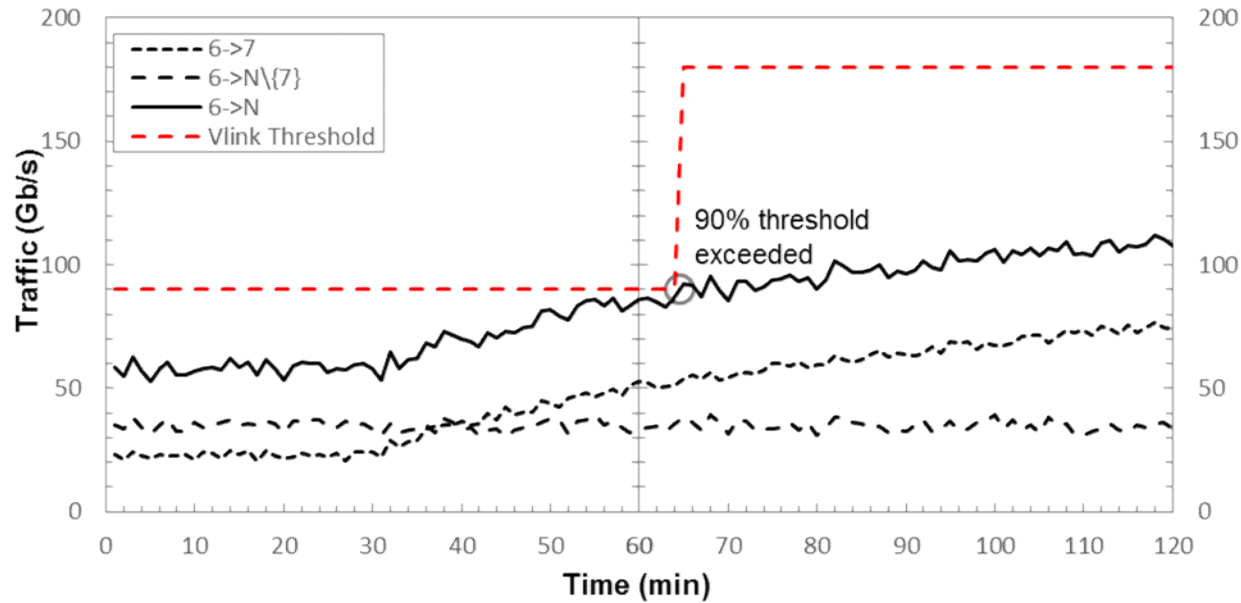

Threshold-based

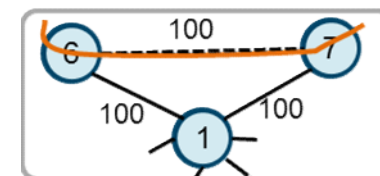
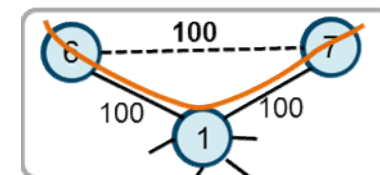

Analytics-based

VNT reconfiguration based on traffic prediction problem

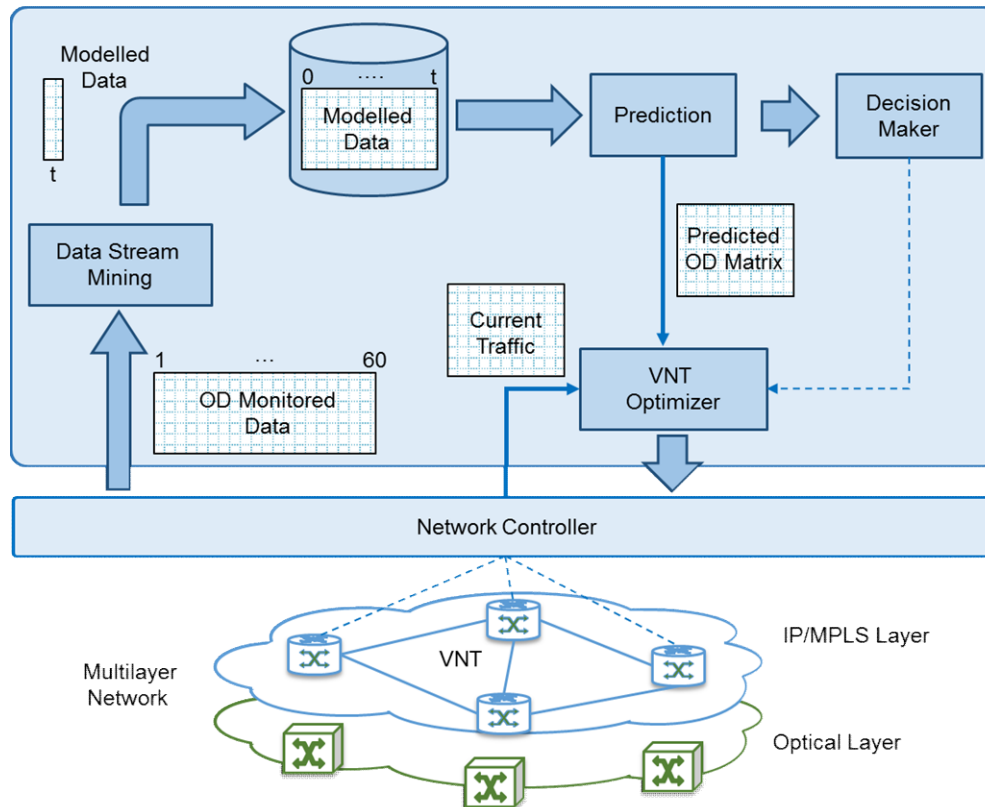

Given:

- An optical network represented by graph $G_O(N, L)$, being N the set of OXC nodes and L the set of fiber links.
- The current VNT represented by graph $G_V(V, E')$, being $V \subseteq N$ the subset of IP/MPLS routers and $E' \subseteq E$ the subset of current vlinks. Set E is the set of all possible vlinks among the IP/MPLS nodes.
- The set P of current lightpaths supporting E' .
- The set and the capacity $Q(v)$ of available transponders for each node v in V .
- The set D of demands currently set-up, specifying source, destination, and requested bitrate.
- The **predicted OD traffic matrix** specifying the predicted bitrate.
- The maximum number k of new vlinks to be added to the VNT.

Find: a reconfigured VNT $G_V^*(V, E^*)$, where $E^* \subseteq E$, and a set $P^* \supseteq P$ of lightpaths supporting E^* .

Objective: Minimize the overall resource utilization to serve both, D and OD sets.

Results

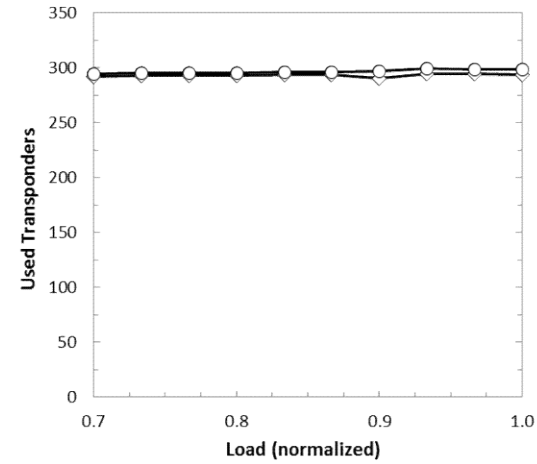
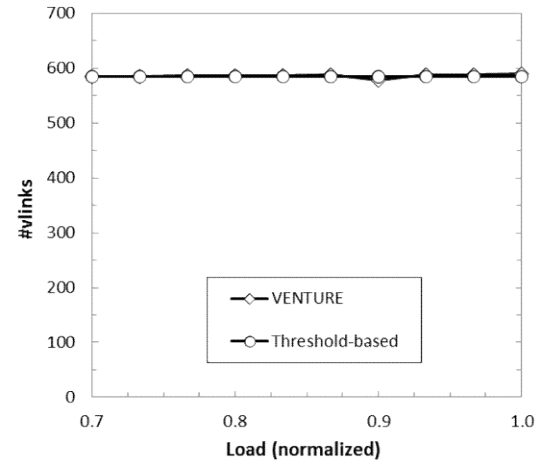
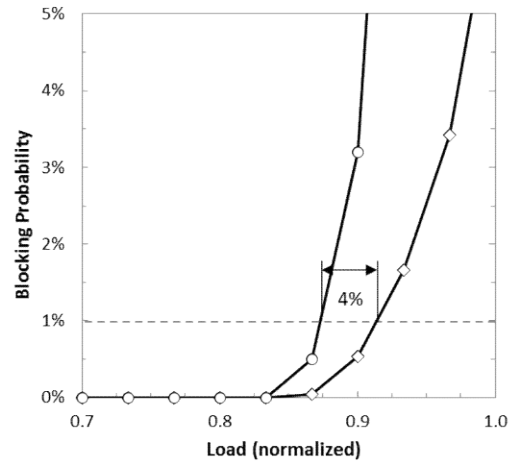

Non-directional Traffic

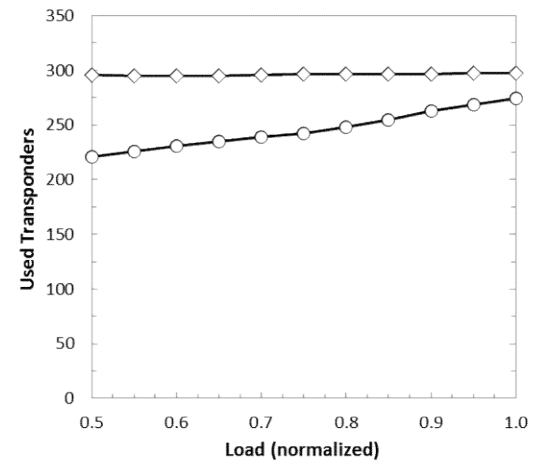
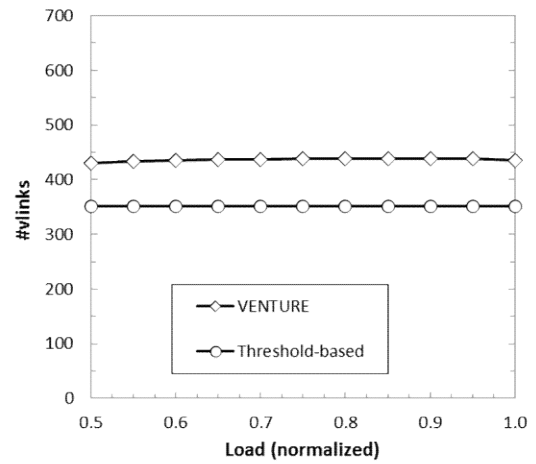
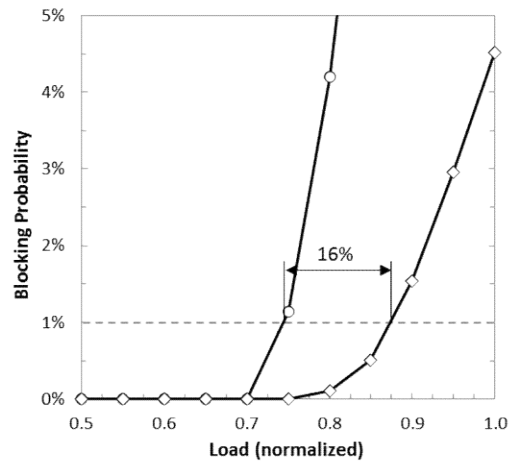

Directional Traffic

Big data network manager architecture

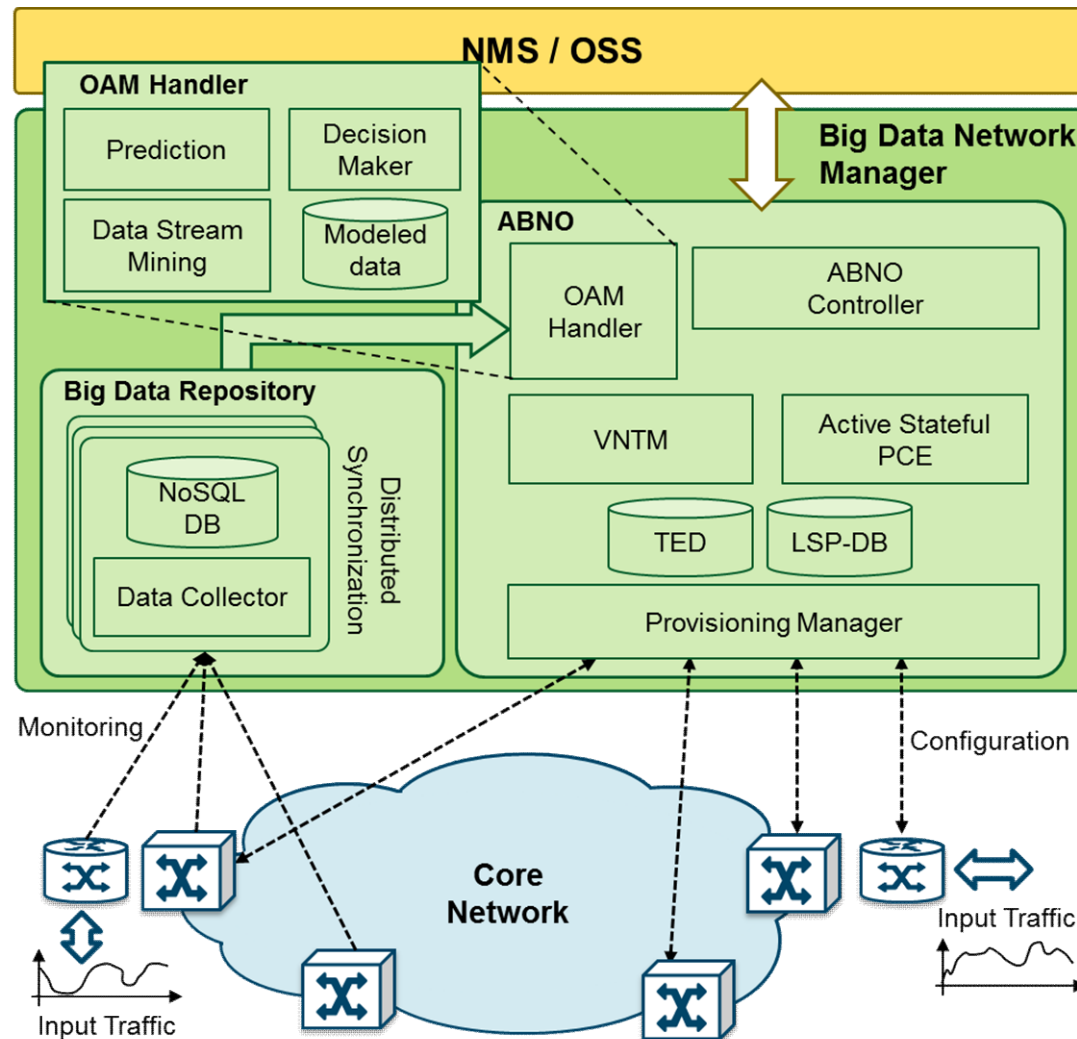

Conclusions

- **Basic RSA-based problems have been reviewed**
- **Off-line planning:**
 - Examples for national IP/MPLS Networks and for gradual migration process from fixed to Flexgrid has been presented.
- **Re-optimization** can be performed to increase network performance.
 - Examples included defragmentation and after failure repair optimization
- **In-operation** planning and **holistic** planning extended the networks life-cycle.
- **Data analytics** were introduced as a way to add cognition to the network.



UNIVERSITAT POLITÈCNICA
DE CATALUNYA

Optical
Communications
Group



Thank you for your attention!

Luis Velasco
lvelasco@ac.upc.edu

March, 2016