

# Dual Time and Frequency Domain Optical Layer Digital Twin

M. Devigili(1), M. Ruiz(1), N. Costa(2), A. Napoli(3), J. Pedro(2), and L. Velasco(1)

(1) Universitat Politècnica de Catalunya (UPC), Barcelona, Spain (mariano.devigili@upc.edu)

(2) Infinera Unipessoal Lda., Carnaxide, Portugal; (3) Infinera, Munich, Germany

**Abstract** *We demonstrate a digital twin for failure detection in optical networks. Artificial neural networks-based models for optical constellation analysis enable predicting the transmitted signal in the time domain whereas analytical models are usually used to estimate their spectral evolution. ©2022 The Author(s)*

## 1. Introduction

Digital Twins (DT) can be defined as a combination of data, models, and algorithms that act as a bridge between real and virtual worlds. DT have been recently proposed to model optical communications [1]. Examples of applications of an optical layer DT are intelligent fault management and misconfiguration detection, where the real optical signal can be compared to the expected one produced by the DT to find discrepancies and estimate their root cause. Note that the same objective can be achieved by applying different methods, like analytical models, simulation, or deep learning (see, e.g., [2]-[4]). The DT, however, provide a more complete characterization of the optical signal, which can be helpful to perform more complete analyses. For instance, employing methods that just estimate the channel's OSNR or only work in the time domain may not be effective to detect a failure in an optical filter. The opposite is also true, by analyzing the received signal bandwidth, it may be difficult to detect excessive noise coming from an optical amplifier.

In our previous work [4], we focused on the time domain and proposed the use of Artificial neural networks (ANN) to model the impairments arising in optical erbium doped fiber amplifiers (EDFAs), optical fibers and filters. Then, the total optical performance degradation in end-to-end lightpaths could be modelled by concatenating such ANNs, from the transmitter to the receiver. In this paper, we extend the work presented in [4] by including also frequency domain models. The new models proposed in this work (implemented in the frequency domain) can be concatenated to the time-domain ones to increase the accuracy of the end-to-end lightpath optical performance. Illustrative use cases are analyzed to show the application of the proposed time and frequency domain digital twin (TF-DT) of the optical layer.

## 2. Optical Layer Digital Twin and Use Cases

We assume reconfigurable optical add drop multiplexers (ROADM) following a route & select

architecture equipped with optical spectrum analyzers (OSA). The optical signal to noise ratio (OSNR) and bandwidth of the desired signal can be derived from the measured optical spectrum. This monitoring carried out in intermediate ROADMs complements these more detailed one performed at the coherent receiver.

An illustrative network scenario with  $n$  ROADMs is represented in Fig. 1. Each ROADM consists of two wavelength selective switches (WSSs) and an EDFA (except the last one). The ROADMs are connected by optical links with which may consist of several fiber spans and inline EDFAs. The proposed TF-DT is also illustrated, consisting of the concatenated ANNs for the time domain analysis of the transmitted data signal whereas analytical models are used for the frequency domain. The ANNs model the propagation of constellation points (CP)s in the ROADMs and into optical links, whereas analytical models are used to model the bandwidth inside the ROADMs. Measurements collected from the network can then be compared to the expected signals generated using the TF-DT.

Let us illustrate the application of the TF-DT through the analysis of the use cases depicted in Fig. 2. In this case, the configuration a) corresponds to normal network operation, i.e., without any failure or misconfiguration; b) illustrates a misconfiguration where a channel is wrongly dropped at an intermediate node instead of being till the end of the fiber link. Instead, a new signal is injected in this node; c) corresponds to a faulty WSS in an intermediate node where there is a Filter shift (FS) or Filter Tightening (FT); d) illustrates the impact of having a too noisy EDFA in an intermediate node; e) corresponds to a misconfiguration causing the erroneous signal extraction at an intermediate node and the injection of another signal, which is afterwards affected by FS and FT at a WSS in another intermediate node (i.e., cases b) and c) together). The objective of this analysis is to determine which models are necessary to build a resilient DT, capable of a multi degree abstraction of the

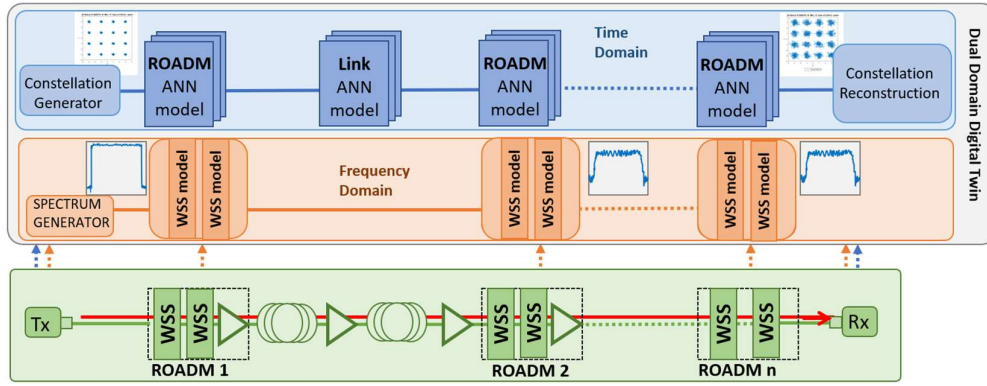

Fig. 1: Dual Domain Digital Twin enabling an extended analysis of the measured signal.

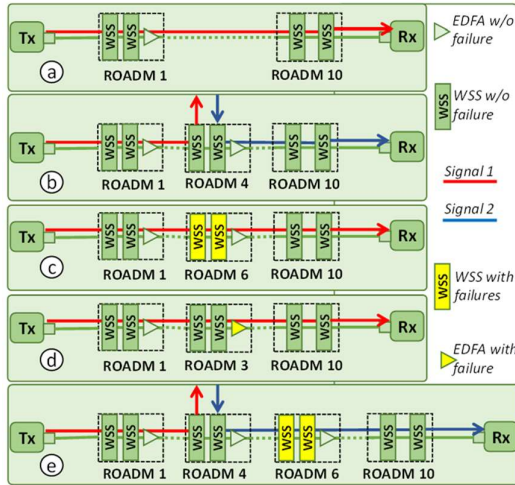

Fig. 2: Considered use cases: normal operation (a), misconfiguration (b), WSS failure (c), EDFA failure (d) and multiple failures (e).

physical layer and enabling the detection of different failures and misconfigurations.

### 3. Models

Fig. 1 shows the model of the envisioned TF-DT. In the time domain, the proposed DT predicts impairments such as GVD, loss and higher order dispersion introduced along the network via concatenated feed-forward ANNs. The Time Domain analyzer consists of three main blocks: *i*) a *constellation generator* with a transmitter model that defines an input optical signal in the time domain and generates its optical constellation. Each constellation point is then sampled and modeled with a Gaussian bivariate distribution. The mean and covariance are extracted employing the gaussian mixture models (GMM)s; *ii*) a propagation model that uses the extracted mean and covariance as features (inputs) of the ANNs. This model is a data-driven end-to-end ML approach based on the concatenation of feed-forward ANNs (i.e., the ROADMs' and links' models) which are trained, tested and validated with synthetic data generated, in this work, using

MATLAB-based coherent system simulator; and *iii*) a constellation reconstruction block that converts the propagated features into a received optical constellation.

Differently, in the frequency domain, a theoretically-calculated optical spectrum is generated to estimate filtering penalties following the model presented in [3]. The frequency domain analyzer consists of two main elements: *i*) a spectrum generator that generates an ideal square pulse shaped by a raised cosine filter and *ii*) an analytical model that emulates a WSS. The impact of the WSS filtering is modelled by concatenating the WSS transfer functions (Fig. 3), resulting in a noise-free version of the optical signal. Optionally, the GNPY open source tool [5] may be used to provide an estimation of the OSNR in this case.

### 4. Results

For the target test cases, a MATLAB digital coherent system simulator was considered to reproduce the physical layer. The simulated scenario emulates a core optical network with ten ROADMs (see Fig. 2) connected by 100km long optical fiber links, each composed of 2 spans of 50km and an EDFA, thus resulting in a total transmission distance of 900 km. We evaluate the performance of the TF-DT considering the transmission of a single 16QAM@64GBd, shaped with a root-raised cosine filter with a roll-off factor of 0.06. The use of a standard single mode fiber with attenuation parameter of 0.21 dB/km and chromatic dispersion parameter of 16.8 ps/nm/km is assumed. The EDFAs, used to fully compensate the fiber and ROADMs losses, are modelled as having a noise figure of 4.5 db. The WSS are modelled as proposed in [6]. Fig. 4 shows the measured (a) and the expected constellation (the gaussian bivariate distribution of only 4 of the total 16 constellation points is shown for clarity) and (b) optical spectra

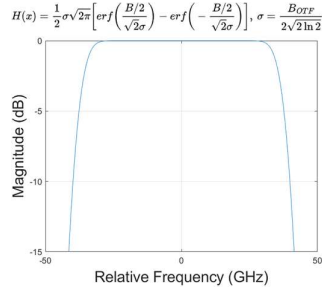

Fig. 3: Transfer function in the TF-DT

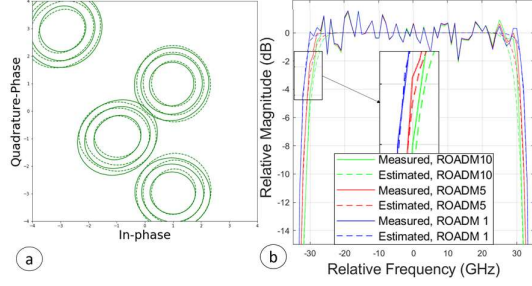

Fig. 4: Expected and measured optical Constellation (a) and spectra (b)

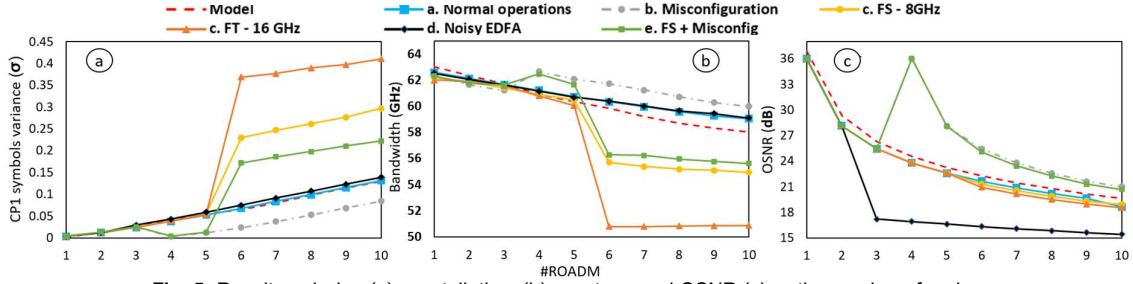

Fig. 5: Result analyzing (a) constellation, (b) spectrum and OSNR (c) vs the number of nodes.

Table 1: Summary of schemes detection.

Model	Use Case				
	a	b	c	d	e
Constellation	yes	yes	yes	no	yes
Spectrum	yes	yes	yes	no	no
OSNR	yes	no	no	yes	no
TF-DT	yes	yes	yes	yes	yes

at ROADM 10 and ROADMs 1, 5 and 10, respectively. The normalized amplitude is plotted to compare the data signal spectra with the noiseless expected one.

Fig. 5 shows the average results as a function of the number of nodes (and distance) obtained after 20 PBRS simulations for each case. The five use cases described in Section 2 are evaluated using four different models: i) the constellation model [4]; ii) the expected spectrum; iii) the GNPpy tool [5]; and the TF-DT. Fig. 5(a) shows the symbol variance of one CP versus the number of nodes. As expected, the variance increases with the number of nodes (and distance).

Fig. 5(b) shows the -3 dB spectral bandwidth versus the number of nodes. As expected, the bandwidth decreases as the number of cascade WSSs (2 WSS/node) increases. Analyzing both symbol variance and spectral bandwidth, we observe that the misconfiguration cases can be easily recognized since both metrics go simultaneously to their minimum and maximum values, respectively, when a new signal is injected in an intermediate node. On the contrary, when a filter failure occurs, the variance of the bandwidth decreases. However, in the case of an EDFA failure -- modelled by adding 10 dB of extra ASE noise to the channel during amplification --

small changes in the variance of the received constellation points were observed while the signal bandwidth remained mostly unchanged.

Finally, Fig.3(c) shows the OSNR as a function of the number of traversed nodes. By analyzing the OSNR evolution it is possible to detect misconfigurations (the OSNR goes to its maximum value) and EDFA failures (the OSNR goes to its minimum value). However, the considered filter failures have only small impact in the OSNR and thus cannot be easily detected using this metric.

The obtained results are summarized in Table 1, where the use cases that can be detected using each model are listed. The results clearly show that the proposed FT-DT is the model with highest potential to detect misconfigurations and failures since it combines analysis in the time and frequency domains. Such combined analysis overcomes the main limitations that each different approach faces when used individually.

## 5. Conclusions

A frequency and time domain digital twin is proposed for failure detection in optical networks. We show that by analyzing the time domain (constellation), the spectrum and the OSNR, a TF-DT can detect and distinguish among several failures and misconfigurations, thus overcoming several limitations of previously proposed approaches.

## Acknowledgements

This project has received funding from the European Union Horizon 2020 MSCA-EID MENTOR (G.A. 956713), the H2020 B5G-OPEN (G.A. 101016663), the MICINN IBON (PID2020-114135RB-I00), and the ICREA Institution.

## References

- [1] D. Wang *et al.*, "The role of digital twin in optical communication: fault management, hardware configuration, and transmission simulation," IEEE Communications Magazine, 2021.
- [2] S. Barzegar *et al.*, "Soft-failure detection, localization, identification, and severity prediction by estimating QoT model input parameters," IEEE Transactions on Network and Service Management (TNSM), vol. 18, pp. 2627-2640, 2021.
- [3] B. Shariati, M. Ruiz, J. Comellas, and L. Velasco, "Learning from the optical spectrum: Failure detection and identification", IEEE J. of Lightwave Technology, vol. 37, pp. 433-440, 2019.
- [4] M. Ruiz, D. Sequeira, and L. Velasco, "Deep Learning -based real-time analysis of lightpath optical constellations [Invited]," IEEE/OPTICA J. of Optical Communications and Networking (JOCN), vol. 14, pp. C70-C81, 2022.
- [5] A. Ferrari *et al.*, "GNPy: an open source application for physical layer aware open optical networks," IEEE/OPTICA J. of Optical Communications and Networking (JOCN), vol. 12, pp. C31-C40, 2020.
- [6] C. Pulikkaseril *et al.*, "Spectral modeling of channel band shapes in wavelength selective switches", Optics Express, vol. 19, pp. 8458-8470, 2011.