

# Computer Networks - *Xarxes de Computadors*

## Outline

- Course Syllabus
- Unit 1: Introduction
- Unit 2. IP Networks
- Unit 3. LANs
- **Unit 4. TCP**
- Unit 5. Network applications

Based on: <https://studies.ac.upc.edu/FIB/grau/XC/#slides>

# Unit 4. TCP

## Outline

- **UDP Protocol**
- ARQ Protocols
- TCP Protocol

## Unit 4. TCP

### UDP Protocol – Introduction: The Internet Transport Layer

- Two protocols are used at the TCP/IP transport layer: User Datagram Protocol (**UDP**) and Transmission Control Protocol (**TCP**).
- **UDP** offers a *datagram service* (non reliable).
- **TCP** offers a *reliable service*.
- Transport layer offers a *communication channel between applications*.
- Transport layer access points (applications) are identified by a **16 bits port numbers**.
- TCP/UDP use the *client/server paradigm*:

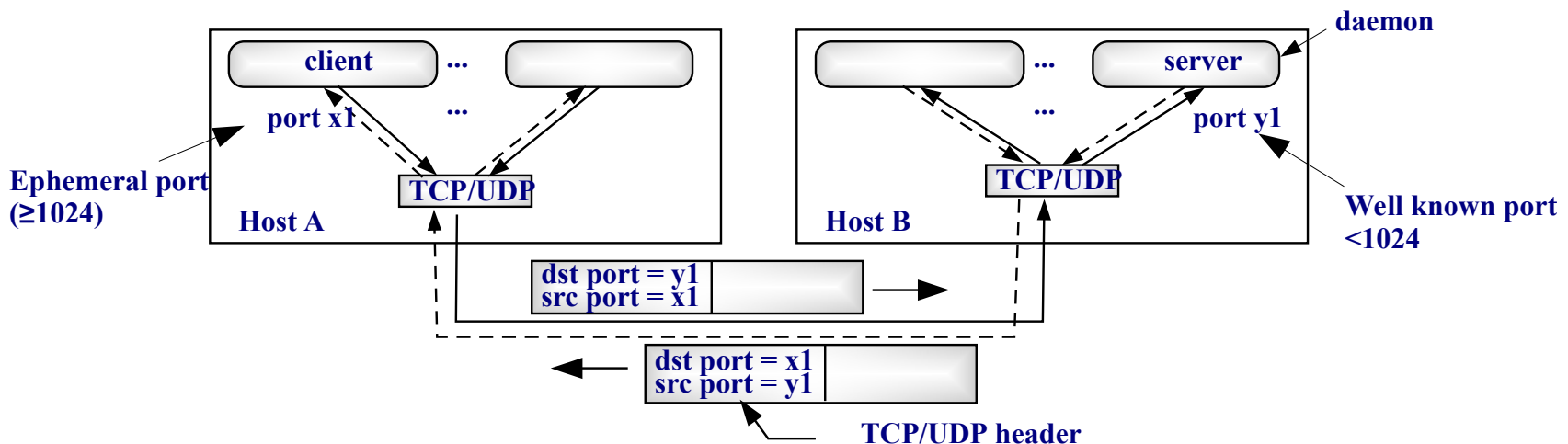

## Unit 4. TCP

### UDP Protocol – Description (RFC 768)

- **Datagram service**: same as IP.
  - Non reliable
  - No error recovery
  - No ack
  - Connectionless
  - No flow control
- UDP PDU is referred to as **UDP datagram**.
- UDP **does not have a Tx buffer**: each *write* operation at application level generates a UDP datagram.
- UDP is typically used:
  - Applications where **short messages** are exchanged: e.g. **DHCP, DNS, RIP**.
  - **Real time applications**: e.g. Voice over IP, videoconferencing, stream audio/video. These applications does not tolerate large delay variations (which would occur using an ARQ).

## Unit 4. TCP

### UDP Protocol – UDP Header

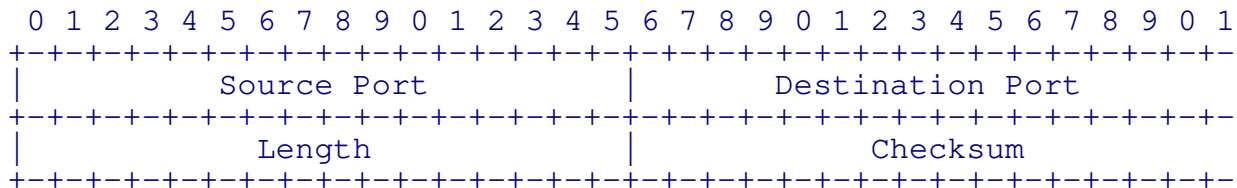

UDP datagram header

- Fixed size of **8 bytes**.
- The **source port** can be set to 0 (zero) if the sending process does not expect messages in response.
- The **length** is in bytes of the UDP header **and UDP data**. The minimum length is 8 bytes (the length of the header).
- The **checksum** is computed including the UDP header without Checksum, the payload and an IP pseudo-header (srcIP, dstIP, protocol). Not mandatory in IPv4 (mandatory in IPv6).

0x11 (Unit 2)

# Unit 4. TCP

## UDP Protocol – UDP Header – Checksum

IPv4 pseudo header format

Offsets	Octet	0								1								2								3							
Octet	Bit	0	1	2	3	4	5	6	7	8	9	10	11	12	13	14	15	16	17	18	19	20	21	22	23	24	25	26	27	28	29	30	31
0	0	Source IPv4 Address																															
4	32	Destination IPv4 Address																															
8	64	Zeroes								Protocol								UDP Length															
12	96	Source Port																Destination Port															
16	128	Length																Checksum															
20	160+	Data																															

Source [https://en.wikipedia.org/wiki/User\\_Datagram\\_Protocol#IPv4\\_pseudo\\_header](https://en.wikipedia.org/wiki/User_Datagram_Protocol#IPv4_pseudo_header)

Same value

- **Zeros:** one byte set to zero.
- **Protocol:** 0x11 (see Unit 2).
- **UDP Length:** the length of the UDP header and data in bytes (including the 2B of the checksum).
- **Checksum:** ‘The 16-bit one's complement of the one's complement sum of a pseudo header of information from the IP header, the UDP header, and the data, padded with zero octets at the end (if necessary) to make a multiple of two octets.’ (RFC768)

# Unit 4. TCP

## Outline

- UDP Protocol
- **ARQ Protocols**
- TCP Protocol

## Unit 4. TCP

### ARQ protocols - Introduction

- **Automatic Repeat reQuest** (ARQ) protocols build a communication channel between endpoints, adding functionalities of the type:
  - Error detection
  - Error recovery
  - Flow control
- **Basic ARQ** Protocols:
  - Stop & Wait
  - Go Back N
  - Selective Retransmission (Selective Repeat)
- Used in:
  - Transport layer: TCP
  - Data link layer: wireless (IEEE 802.11)
- TCP uses a variant of Go-Back-N (with SACK -see TCP slides- it uses Selective Repeat)

Recall: IP does not provide a reliable communication channel

# Unit 4. TCP

## ARQ protocols - Introduction

### ARQ Ingredients

- **Connection oriented**
- **Tx/Rx buffers**
- **Acknowledgments (ack)**
- Acks can be *piggybacked* in information PDUs sent in the opposite direction
- **Retransmission Timeout (RTO)**
- **Sequence Numbers**

Recall: connection oriented protocol vs. connectionless protocol

Connection oriented:  
Phase 1: connection establishment  
Phase 2: data stream  
Phase 3: connection termination

NACK (negative ACK) to indicate some kind of error

Send ACK in data packages sent in the opposite direction

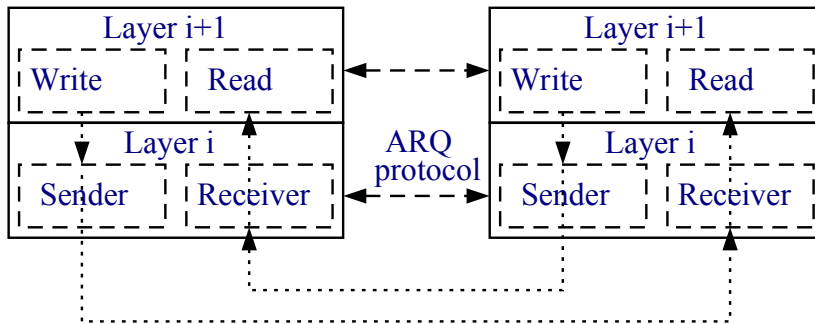

ARQ Protocol Architecture

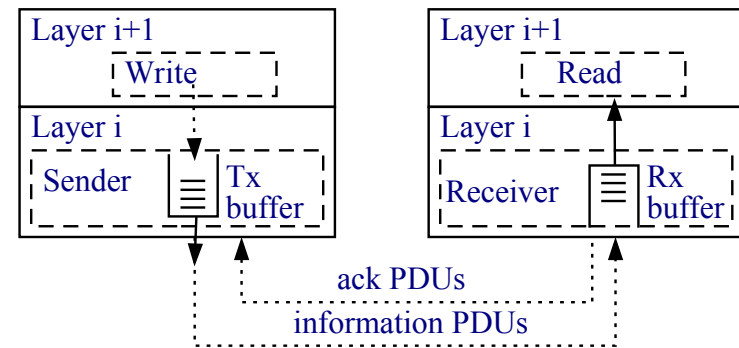

ARQ Protocol Implementation (one way)

## Unit 4. TCP

### ARQ Protocols - Assumptions

- We shall focus on the the transmission in **one direction**.
- We shall assume a **saturated source**: There is always information ready to send.
- We shall assume **full duplex** links.
- Protocol over a line of  **$D$  m distance** and  **$v_t$  [bps] bitrate**.
- Propagation speed of  **$v_p$  [m/s]**, thus, **propagation delay** of  $D/v_p$  [s].
- We shall refer to a **generic layer**, where the sender sends Information PDUs ( $I_k$ ) and the receiver sends ack PDUs ( $A_k$ ).
- Frames carrying  $I_k$  and  $A_k$ , are Tx using  $L_I$  and  $L_A$  bits, thus the **Tx times** are respectively:  $t_t = L_I/v_t$  and  $t_a = L_A/v_t$  s.

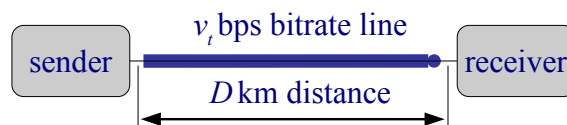

## Unit 4. TCP

### ARQ Protocols - Stop & Wait

1. When the **sender** is ready: (i) allows writing from upper layer, (ii) builds  $I_k$ , (iii)  $I_k$  goes down to data-link layer and Tx starts.
2. When  $I_k$  completely arrives to the **receiver**: (i) it is read by the upper layer, (ii)  $A_k$  is generated,  $A_k$  goes down to data-link layer and Tx starts.
3. When  $A_k$  completely arrives to the **sender**, goto 1.

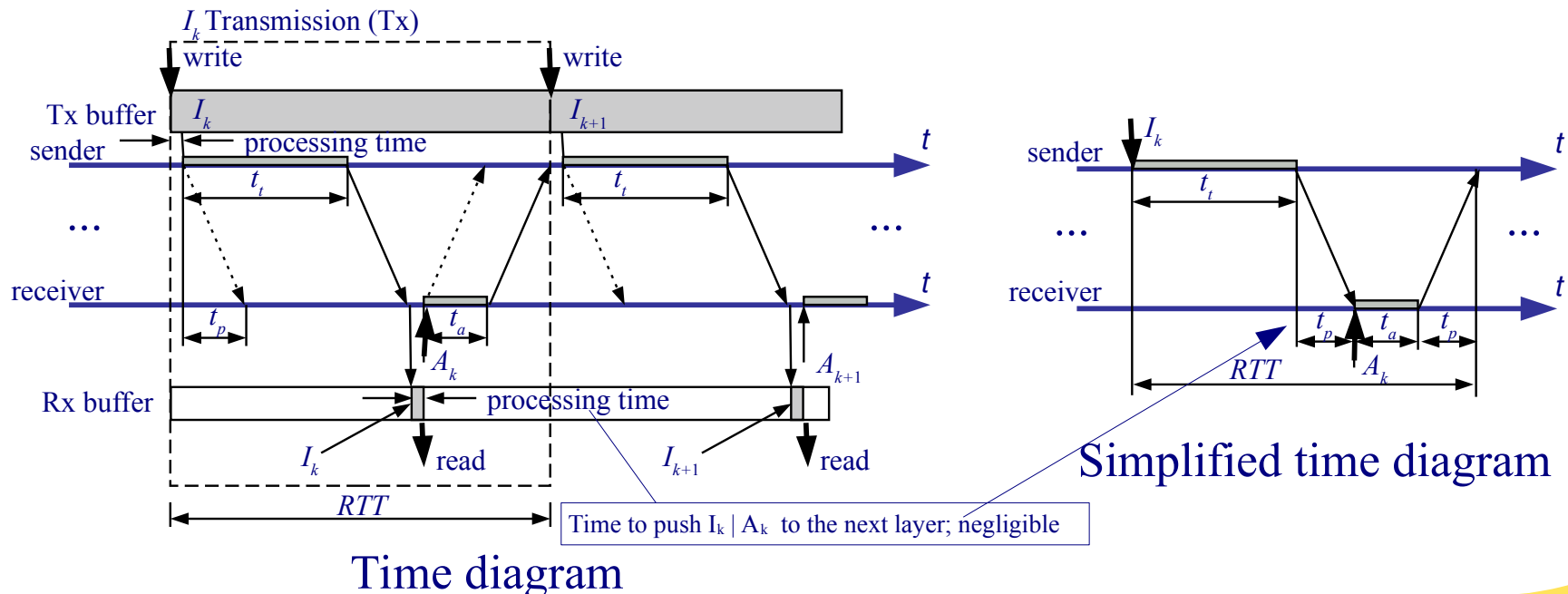

## Unit 4. TCP

### ARQ Protocols - Stop & Wait Retransmission

- Each time the sender Tx a PDU, a **RTO** is started.
- If the information PDU do not arrives, or arrives with errors, **no ack** is sent.
- When RTO expires, the sender **ReTx** (retransmit) the PDU.

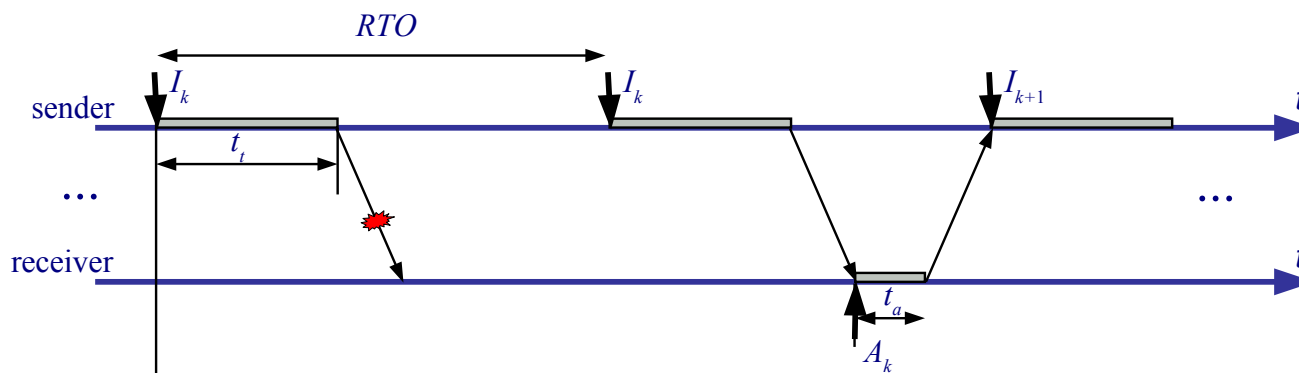

# Unit 4. TCP

## ARQ Protocols – Why sequence numbers are needed?

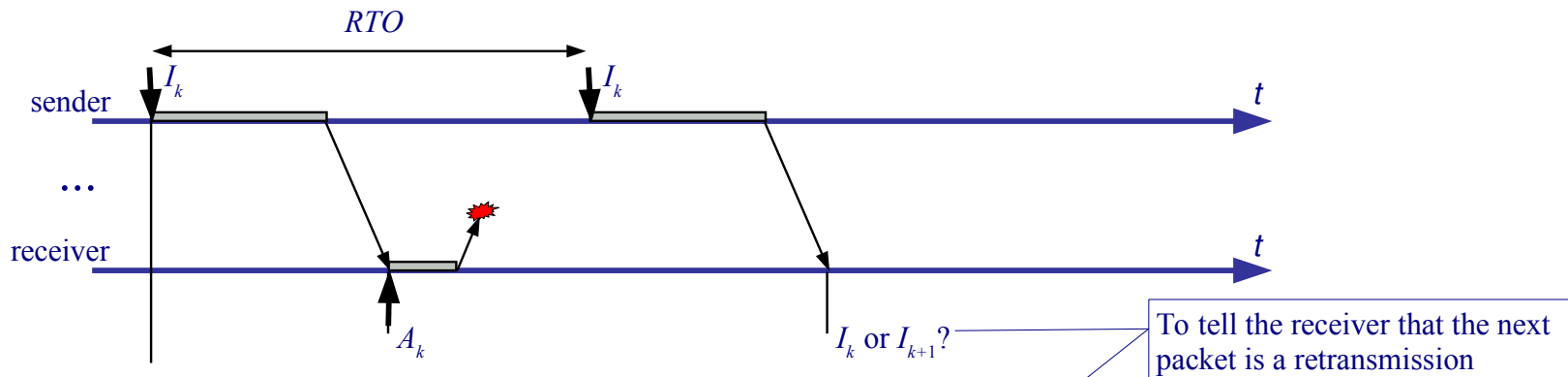

Need to number **information PDUs**

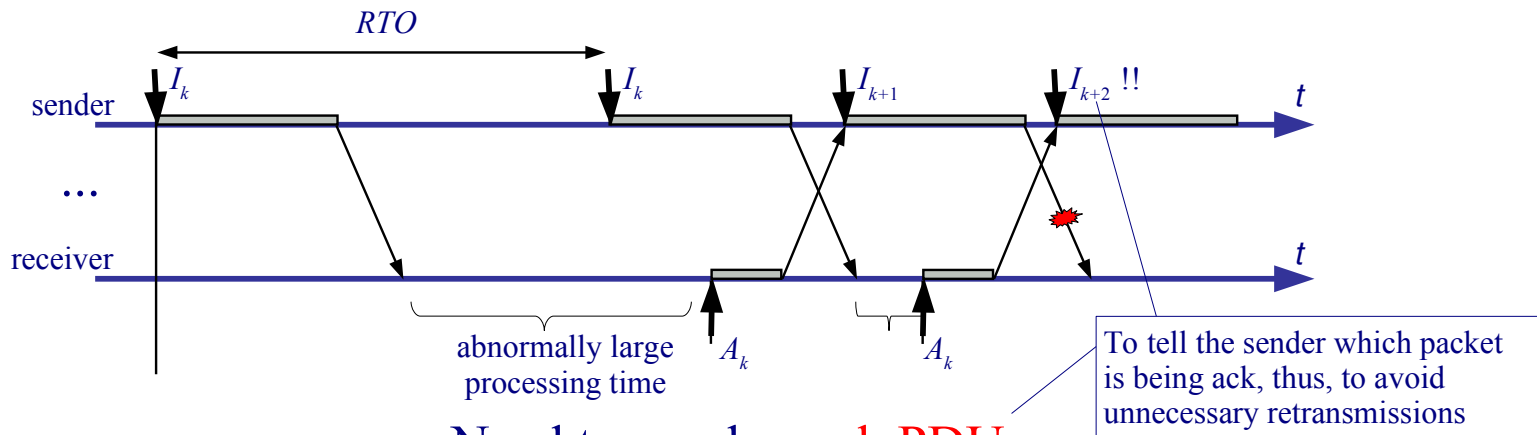

Need to number **ack PDUs**

## Unit 4. TCP

### ARQ Protocols – Notes on computing the efficiency (channel utilization)

- **Line bitrate** (*velocitat de transmissió de la línia*):  $v_t = 1/t_b$ , [bps]
- **Throughput** (*velocitat efectiva*)  $v_{ef}$  = number of inf. bits / obs. time, [bps]
- **Efficiency** or channel utilization  $E = v_{ef} / v_t$  (times 100, in percentage)

The average transmission rate of the user data in bps

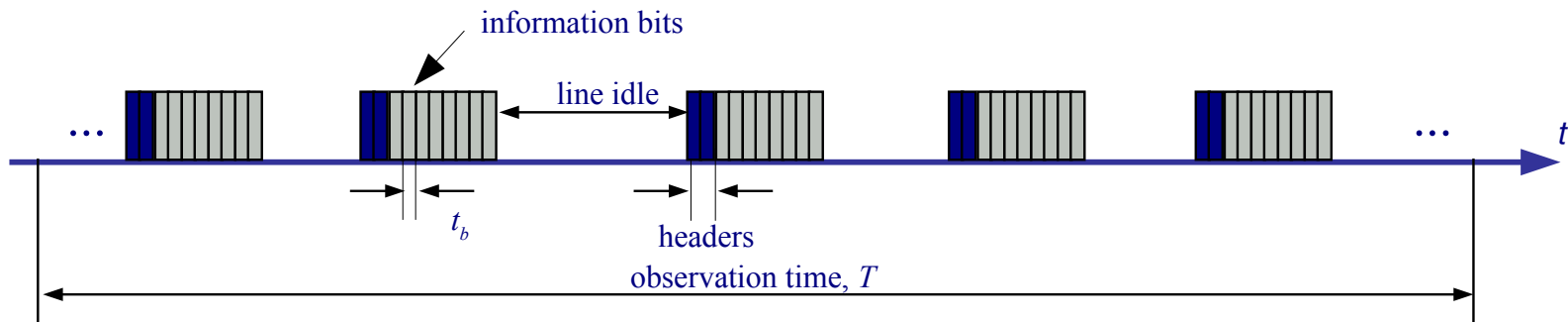

$$E = \frac{v_{ef}}{v_t} = \frac{\#info\ bits / T}{1/t_b} = \left\{ \begin{array}{l} \frac{\#info\ bits \times t_b}{T} = \frac{\text{time Tx information}}{T} \\ \frac{\#info\ bits}{T/t_b} = \frac{\#info\ bits}{\#bits\ at\ line\ bitrate} \end{array} \right.$$

## Unit 4. TCP

### ARQ Protocols – Stop & Wait efficiency

- Assuming no errors (**maximum efficiency**), the Tx is periodic, with period  $RTT$ .
- $E_{protocol}$ : We do not take into account headers.

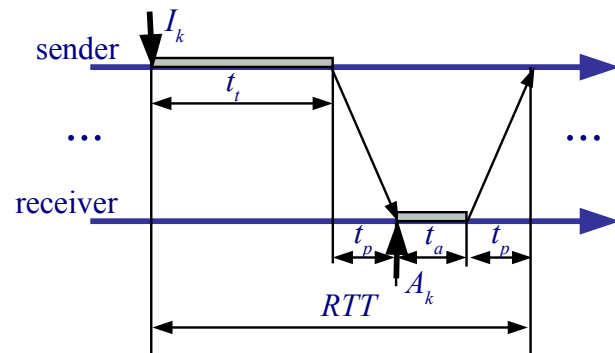

$$E_{protocol} = \frac{t_t}{T_C} = \frac{t_t}{t_t + t_a + 2t_p} =$$

$$\frac{t_t}{t_t + 2t_p} \simeq \frac{1}{1 + 2a}, \text{ where } a = \frac{t_p}{t_t}$$

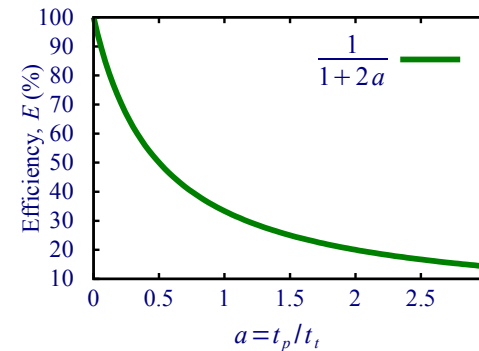

## Unit 4. TCP

### ARQ Protocols – Continuous Tx Protocols

- Goal: Allow high efficiency independently of propagation delay.
- Without errors:  $E = 100\%$
- PDUs transmitted “back-to-back” (i.e. without dealy)

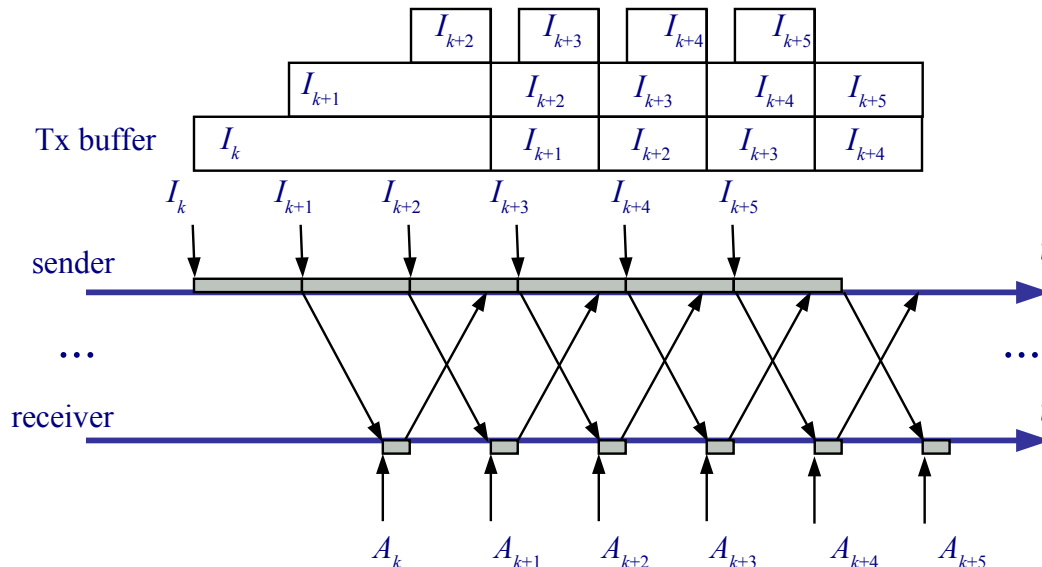

## Unit 4. TCP

### ARQ Protocols – Go Back N

- **Cumulative acks:**  $A_k$  confirm  $I_i$ ,  $i \leq k$  i.e.  $A_k$  confirms all PDUs until  $k$
- If the sender receives an **error or out of order PDU**: Do not send acks, discards all PDU until the expected PDU arrives. Thus, the receiver does not store out of order PDUs.
- When a **RTO** occurs, the sender *go back* and starts Tx from that PDU.

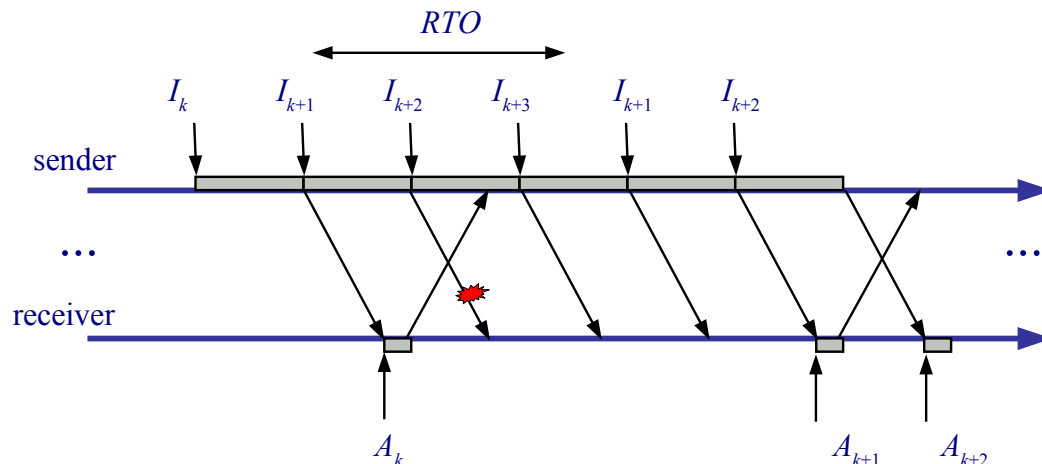

## Unit 4. TCP

### ARQ Protocols – Selective Retransmission (selective repeat)

- The same as Go Back N, but:
  - The sender only ReTx a PDU when a **RTO** occurs.
  - The **receiver stores out of order PDUs**, and ack all stored PDUs when missing PDUs arrive.

The implementation of the receiver is more complex because PDUs must be reordered

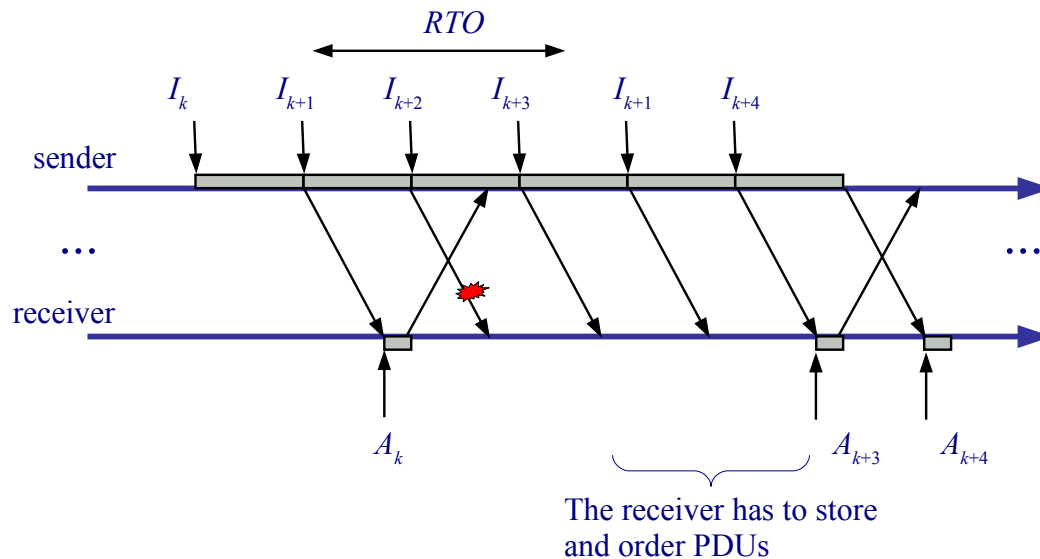

## Unit 4. TCP

### ARQ Protocols – Flow Control and Sliding Window Protocols

- ARQ are also used for flow control. **Flow control** consists on avoiding the sender to Tx at higher PDU rate than can be consumed by the receiver.
- With **Stop & Wait**, if the receiver is slower, acks are delayed and the sender reduces the throughput.
- With **continuous Tx protocols**: A **Tx window** is used. The window is the maximum number of non-ack PDUs that can be Tx. If the Tx window is exhausted, the sender stales.
- **Stop & Wait** is a window protocol with Tx window = 1 PDU.
- Furthermore, the Tx window allows **dimensioning** the Tx buffer, and the Rx buffer for Selective Retransmission: No more the Tx window PDUs need to be stored.

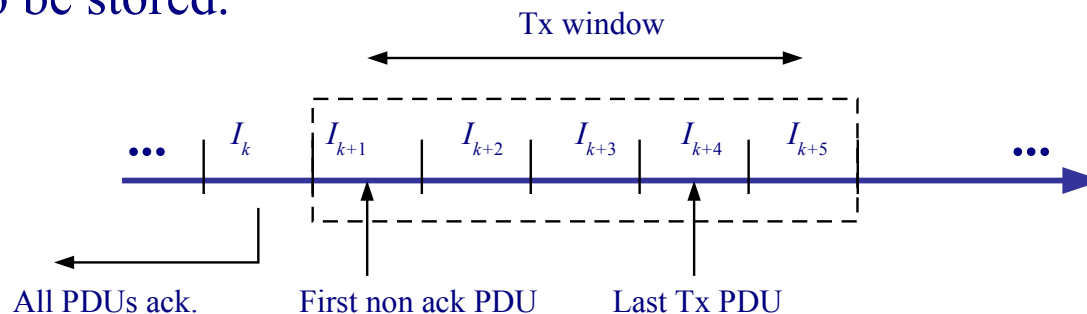

# Unit 4. TCP

## ARQ Protocols – Optimal Tx window

- **Optimal window:** Minimum window that allows the maximum throughput.
- Optimal window example:

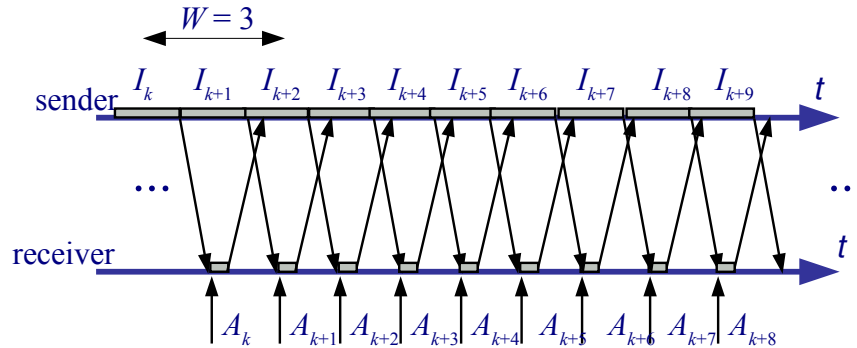

• Formula:

$$W_{opt}[PDU] = \left\lceil \frac{RTT}{t_t} \right\rceil$$

$\lceil \cdot \rceil$  stands for ceiling function

- Non optimal window example:

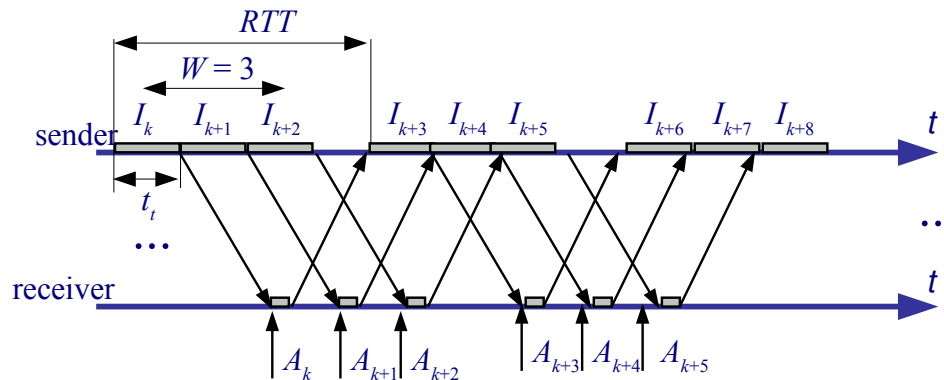

## Unit 4. TCP

### ARQ Protocols – Optimal Tx window

$W_{opt}$  is referred to as the **bandwidth delay product**:

Recall:  $W_{opt}$  is the min. win. that allows max throughput, i.e.  $v_{ef}$

$$W_{opt}[\text{PDU}] = \left\lceil \frac{\text{RTT}}{t_t} \right\rceil = \lceil v_{ef}^{max} [\text{PDU/s}] \times \text{RTT}[\text{s}] \rceil$$

In bytes:

$$W_{opt}[\text{bytes}] \approx v_{ef}^{max} [\text{bytes/s}] \times \text{RTT}[\text{s}] = \frac{v_{ef}^{max} [\text{bps}]}{8 [\text{bits/byte}]} \times \text{RTT}[\text{s}]$$

**Example:**

for  $v_{ef} = 4 \text{ Mbps}$  and  $\text{RTT} = 200 \text{ ms}$  we need

$$W_{opt} = v_{ef} \times \text{RTT} = \frac{4 \times 10^6 \text{ bps}}{8 [\text{bits/byte}]} \times 200 \times 10^{-3} \text{ s} = 100 \text{ kbyte}$$

Thus, we need a window  $\geq 100 \text{ kbyte}$  to reach  $4 \text{ Mbps}$  with an  $\text{RTT}=200 \text{ ms}$ .

# Unit 4. TCP

## Outline

- UDP Protocol
- ARQ Protocols
- **TCP Protocol**

## Unit 4. TCP

### TCP Protocol – Description (RFC 793)

- **Reliable service** (ARQ with **variable window**)
  - Error recovery
  - Connection oriented
  - **Flow control**: Adapt throughput to the receiver
  - **Congestion control**: Adapt throughput to network
- **Segments of optimal size**: Maximum Segment Size (**MSS**).
  - MSS adjusted using MTU path discovery: send datagrams with Don't Fragment bit set, and reduce MSS upon receiving ICMP error messages.
- TCP PDU is referred to as **TCP segment**.
- TCP is typically used:
  - Applications requiring reliability: Web, ftp, ssh, telnet, mail, ...

# Unit 4. TCP

## TCP Protocol – Basic operation

- TCP sender immediately sends the segments allowed by the window
- Upon segment arrival TCP receiver immediately sends an ack (unless delayed ack is used) without waiting for the upper layer to read the data.

- Ack are **cumulative**

- ARQ window protocol, with **variable window**:  $[B] \text{ wnd} = \min(\text{awnd}, \text{cwnd})$

- The **advertised window (awnd)** [B] is used for flow control.
- The **congestion window (cwnd)** [B] is used for congestion control.

The Tx window

The awnd from the receiver

awnd is set by the receiver. E.g. to slow down the tx rate the receiver shrinks the awnd. The sender stores the receiver's awnd as the max number of bytes sent without confirmation

awnd is also known as Rx window

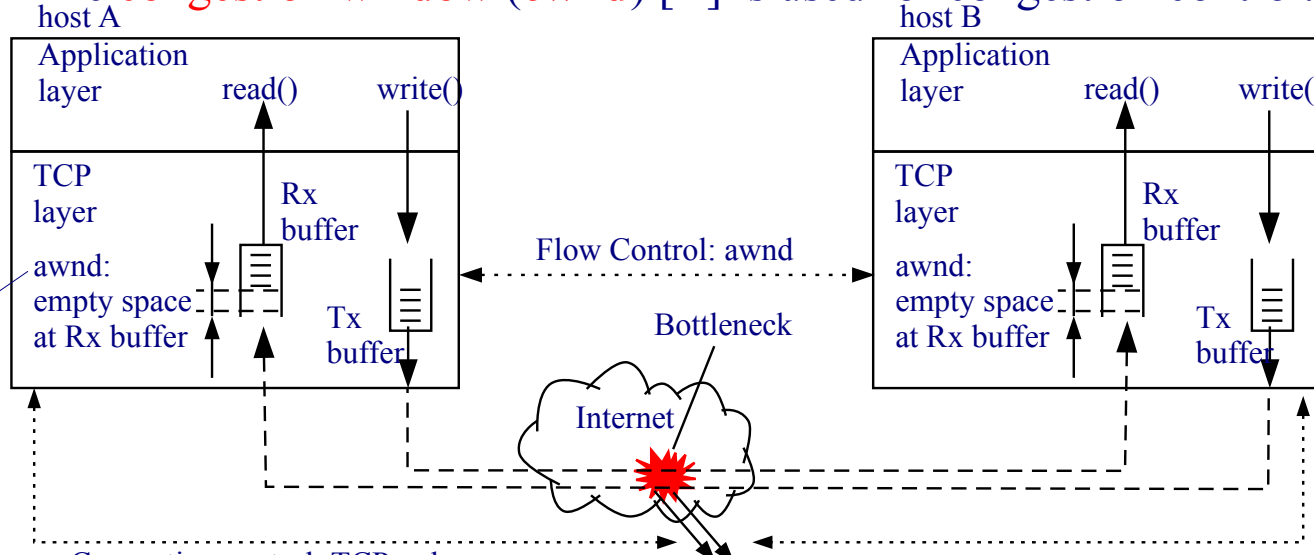

The awnd announced. Part of the TCP header, (thus, updated in every packet) because it may change frequently

Congestion control: TCP reduce the congestion window (cwnd) when losses are detected.

# Unit 4. TCP

## TCP Protocol – Delayed acks

- TCP connections can be classified as:
  - **Bulk**: (e.g. web, ftp) There are always bytes to send. TCP send MSS bytes.
  - **Interactive**: (eg. telnet, ssh) The user interacts with the remote host.
- In bulk connections sending an ack every data segment can unnecessarily send too many small segments. Solution: **Delayed acks**.

**Delayed ack**. It is used to reduce the amount of acks. Consists of sending **1 ack each 2 MSS** segments whenever possible under the time limit of 200 ms. Acks are always sent in case of receiving out of order segments.

tcpdump example (bulk transfer):

Remark: After SYN tcpdump extracts the initial sequence number from the sequence numbers

```

...
11:27:13.798849 147.83.32.14.ftp > 147.83.35.18.3020: P 9641:11089(1448) ack 1 win 10136 (DF)
11:27:13.800174 147.83.32.14.ftp > 147.83.35.18.3020: P 11089:12537(1448) ack 1 win 10136 (DF)
11:27:13.800191 147.83.35.18.3020 > 147.83.32.14.ftp: . 1:1(0) ack 12537 win 31856 (DF)
11:27:13.801405 147.83.32.14.ftp > 147.83.35.18.3020: P 12537:13985(1448) ack 1 win 10136 (DF)
11:27:13.802771 147.83.32.14.ftp > 147.83.35.18.3020: P 13985:15433(1448) ack 1 win 10136 (DF)
11:27:13.802788 147.83.35.18.3020 > 147.83.32.14.ftp: . 1:1(0) ack 15433 win 31856 (DF)
...
    
```

It's a download

Lenght (11089 - 9641 = 1448)

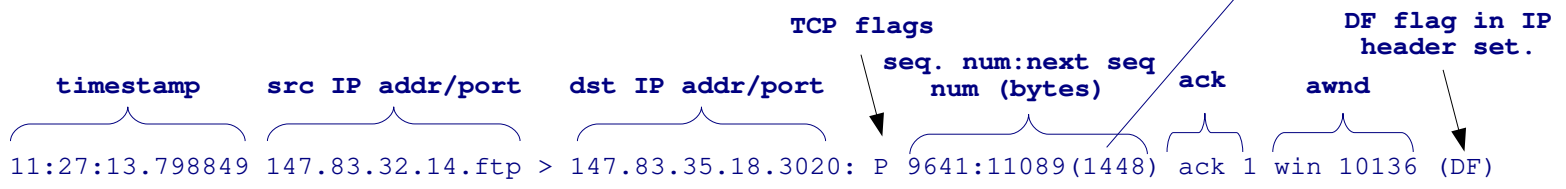

# Unit 4. TCP

## TCP Protocol – TCP Header

Note: The length of the data section is not specified because it is not required at implementation level (the TCP stack just does a sizeof(buf) to find out how much data a segment has). However, it can be calculated by subtracting the combined length of the segment header and IP header from the total IP packet length specified in the IP header.

Conversely, the UDP includes the length because this data is needed at implementation level (obtaining it from the IP header is not acceptable at implementation level because it implies to mix data from different layers and because it cannot be assumed that it runs over IP).

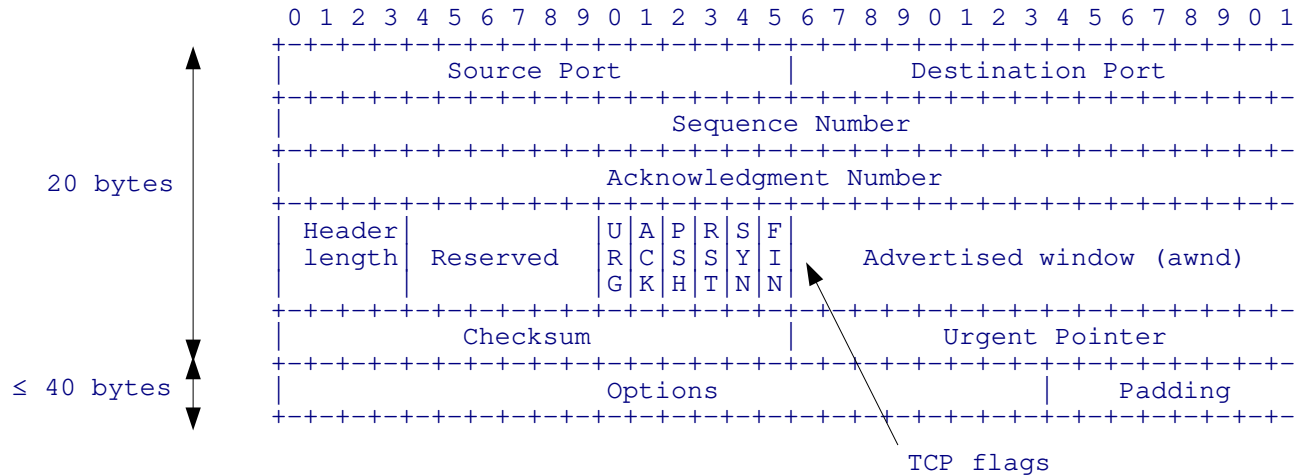

- Variable size: **Fixed fields of 20 bytes + options** (15x4 = 60 bytes max.).
- The **header length** is in 32-bit words. Between 5 and 15).
- **Reserved** for future protocol extensions (currently 3bits already in use).
- Like in UDP, the **checksum** is computed using an IP pseudo-header:

In TCP it is mandatory

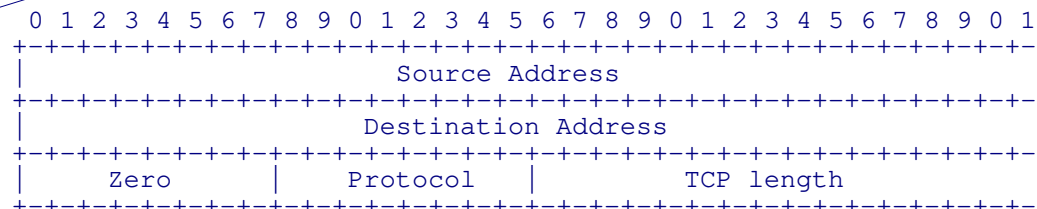

## Unit 4. TCP

### TCP Protocol – TCP Flags

- **URG** (Urgent): The Urgent Pointer is used. It points to the first urgent byte. Rarely used. Example: ^C in a telnet session.
- **ACK**: The ack field is used. Always set except for the first segment sent by the client.
- **PSH** (Push): The sender indicates to “push” all buffered data to the receiving application. Most BSD derived TCPs set the PSH flag when the send buffer is emptied.
- **RST** (Reset): Abort the connection.
- **SYN**: Used in the connection setup (*three-way-handshaking*, **TWH**). Only the first packet sent from each end should have this flag set (bcs it synchronizes sequence numbers). Some other flags and fields change meaning based on this flag.
- **FIN**: Used in the connection termination. Only set in the last packet from the sender.

If set (1), this is the initial sequence number, thus, the receiver has to acknowledge this sequence number plus one. Otherwise (0), this is the accumulated seq. num. of the first data byte of this segment for the current session.

# Unit 4. TCP

## TCP Protocol – TCP Flags

- tcpdump example:

3624662632+1

```

09:33:02.556785 IP 147.83.34.125.24374 > 147.83.194.21.80: S 3624662632:3624662632(0) win 5840
<mss 1460,sackOK,timestamp 531419155 0,nop,wscale 7>
09:33:02.558054 IP 147.83.194.21.80 > 147.83.34.125.24374: S 2204366975:2204366975(0) ack
3624662633 win 5792 <mss 1460,sackOK,timestamp 3872304344 531419155,nop,wscale 2>
09:33:02.558081 IP 147.83.34.125.24374 > 147.83.194.21.80: . ack 1 win 46 <nop,nop,timestamp
531419156 3872304344>
09:33:02.558437 IP 147.83.34.125.24374 > 147.83.194.21.80: P 1:627(626) ack 1 win 46
<nop,nop,timestamp 531419156 3872304344>
09:33:02.559146 IP 147.83.194.21.80 > 147.83.34.125.24374: . ack 627 win 1761 <nop,nop,timestamp
3872304345 531419156>
09:33:02.559507 IP 147.83.194.21.80 > 147.83.34.125.24374: P 1:271(270) ack 627 win 1761
<nop,nop,timestamp 3872304345 531419156>
09:33:02.559519 IP 147.83.34.125.24374 > 147.83.194.21.80: . ack 271 win 54 <nop,nop,timestamp
531419156 3872304345>
09:33:02.560154 IP 147.83.194.21.80 > 147.83.34.125.24374: . 271:1719(1448) ack 627 win 1761
<nop,nop,timestamp 3872304345 531419156>
09:33:02.560167 IP 147.83.34.125.24374 > 147.83.194.21.80: . ack 1719 win 77 <nop,nop,timestamp
531419156 3872304345>
09:33:02.560256 IP 147.83.194.21.80 > 147.83.34.125.24374: . 1719:3167(1448) ack 627 win 1761
<nop,nop,timestamp 3872304345 531419156>
09:33:02.560261 IP 147.83.34.125.24374 > 147.83.194.21.80: . ack 3167 win 100 <nop,nop,timestamp
531419156 3872304345>
...

```

TCP flags

**S**: SYN

**P**: PUSH

.. No flag (except ack) is set

Note: After SYN tcpdump extracts the initial sequence number from the sequence numbers

## Unit 4. TCP

### TCP Protocol – TCP Options

“suggest” to the other end

- **Maximum Segment Size (MSS)**: Used in the TWH to initialize the MSS. Only with SYN set.
  - Common values in IPv4:
    - **MSS 1460**: 1500-40 (MTU [1500B] - (IPv4 header [20B] + TCP header without options [20B]))
    - **MSS 1448**: 1500-52 (MTU [1500B] - (IPv4 header [20B] + TCP [20B] with timestamp options [10B] and 2 nops [1B])). Currently the most common value.
- **Window Scale factor**: Used in the TWH. The awnd is multiplied by  $2^{\text{Window Scale}}$  (i.e. the window scale indicates the number of bits to left-shift awnd). It allows using awnd larger than  $2^{16}$  bytes. Only with SYN set.
- **Timestamp**: Used to compute the Round Trip Time (RTT). Is a 10 bytes option, with the timestamp clock of the TCP sender, and an echo of the timestamp of the TCP segment being ack. Used to set RTO.
- **SACK**: In case of errors, indicate blocks of consecutive correctly received segments for Selective Retransmission. Only with SYN set.
- **NOP**: Used for padding (1B).
- Etc. (~35 in total; may be extended in the future)

Remark: In TCP the options are frequently used (contrary to IP)

# Unit 4. TCP

## TCP Protocol – Connection Setup and Termination

- The **client** always send the 1<sup>st</sup> SYN segment. Conversely, the FIN might be sent by the server first
- **Three-way handshaking** segments have payload = 0.
- SYN and FIN segments **consume 1 sequence number**.
- **Initial sequence number** is random.

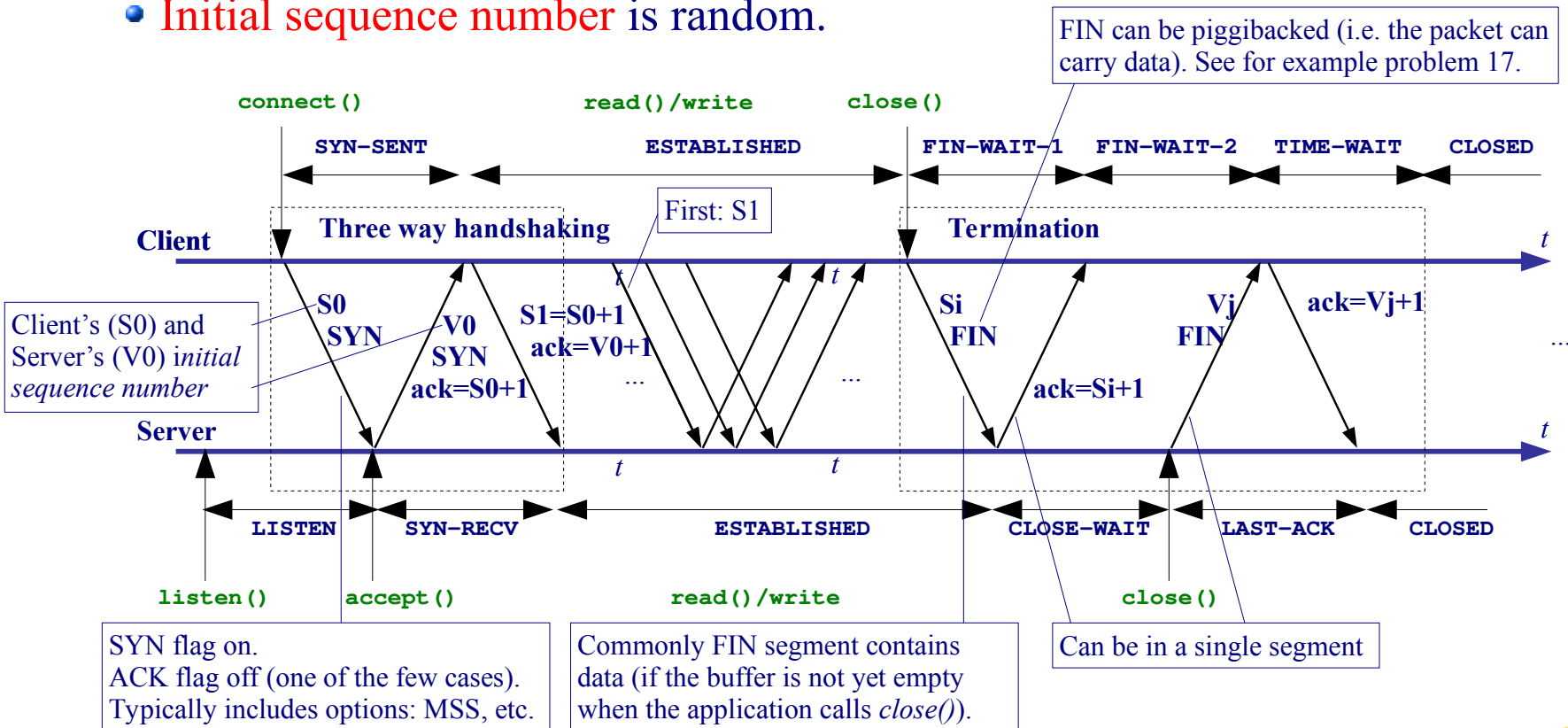



# Unit 4. TCP

## TCP Protocol – tcpdump example (web page download)

(a) win is recommended to be a multiple of mss for optimisation reasons

```

Data stream
1 12:30:37.069541 IP 147.83.34.125.17788 > 147.83.32.82.80: S 3473661146:3473661146(0) win 5840 <mss 1460,sackOK,timestamp 296476754 0,nop,wscale 7>
2 12:30:37.070021 IP 147.83.32.82.80 > 147.83.34.125.17788: S 544373216:544373216(0) ack 3473661147 win 5792 <mss 1460,sackOK,timestamp 1824770623 296476754,nop,wscale 2>
3 12:30:37.070038 IP 147.83.34.125.17788 > 147.83.32.82.80: . ack 1 win 46 <nop,nop,timestamp 296476754 1824770623>
4 12:30:37.072763 IP 147.83.34.125.17788 > 147.83.32.82.80: P 1:602(601) ack 1 win 46 <nop,nop,timestamp 296476754 1824770623>
5 12:30:37.073546 IP 147.83.32.82.80 > 147.83.34.125.17788: . ack 602 win 1749 <nop,nop,timestamp 1824770627 296476754>
6 12:30:37.075932 IP 147.83.32.82.80 > 147.83.34.125.17788: P 1:526(525) ack 602 win 1749 <nop,nop,timestamp 1824770629 296476754>
7 12:30:37.075948 IP 147.83.34.125.17788 > 147.83.32.82.80: . ack 526 win 54 <nop,nop,timestamp 296476755 1824770629>
8 12:30:53.880704 IP 147.83.32.82.80 > 147.83.34.125.17788: F 526:526(0) ack 602 win 1749 <nop,nop,timestamp 1824787435 296476755>
9 12:30:53.920354 IP 147.83.34.125.17788 > 147.83.32.82.80: . ack 527 win 54 <nop,nop,timestamp 296480966 1824787435>
10 12:30:56.070200 IP 147.83.34.125.17788 > 147.83.32.82.80: F 602:602(0) ack 527 win 54 <nop,nop,timestamp 296481504 1824787435>
11 12:30:56.070486 IP 147.83.32.82.80 > 147.83.34.125.17788: . ack 603 win 1749 <nop,nop,timestamp 1824789625 296481504>
    
```

- 1, 2, 3: Three way-handshake
- 4: The client (147.83.34.125) requests a web page (e.g. index.html)
- 5: The server (147.83.32.82) ACKs the client's request
- 6: The server sends the web page in a single segment
- 7: The client ACKs the segment containing the web page
- 8: The server starts the connection termination
- 9: The client ACKs server's termination
- 10: The client starts the connection termination
- 11: The server ACKs client's termination

Recall: Flags  
 S SYN  
 · ACK only  
 P Push  
 F FIN

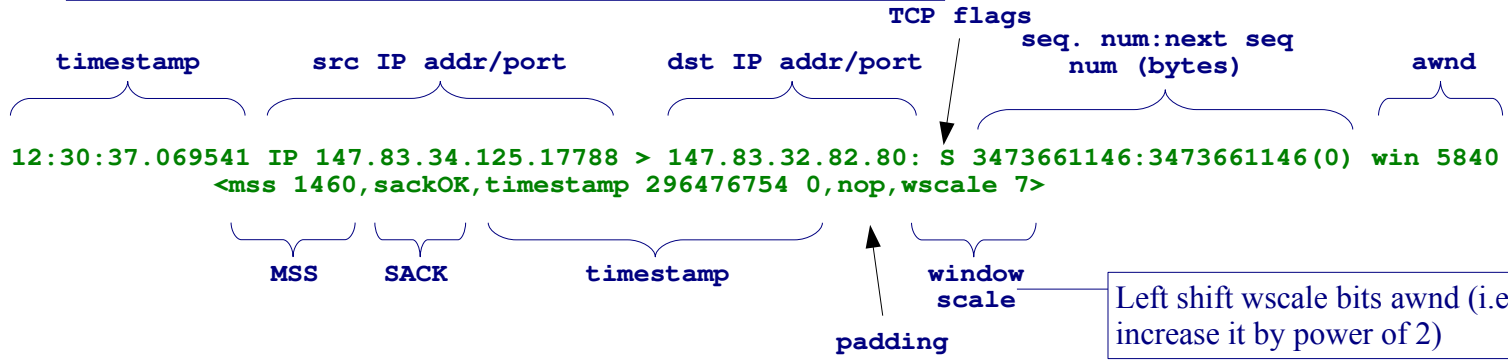

# Unit 4. TCP

## TCP Protocol – State diagram (simplified)

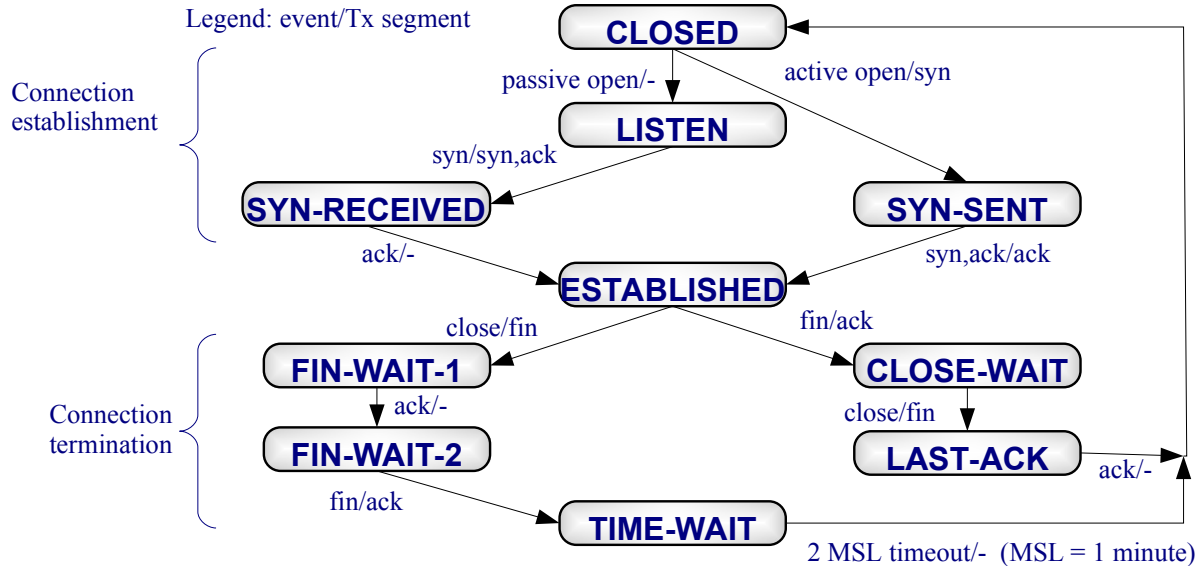
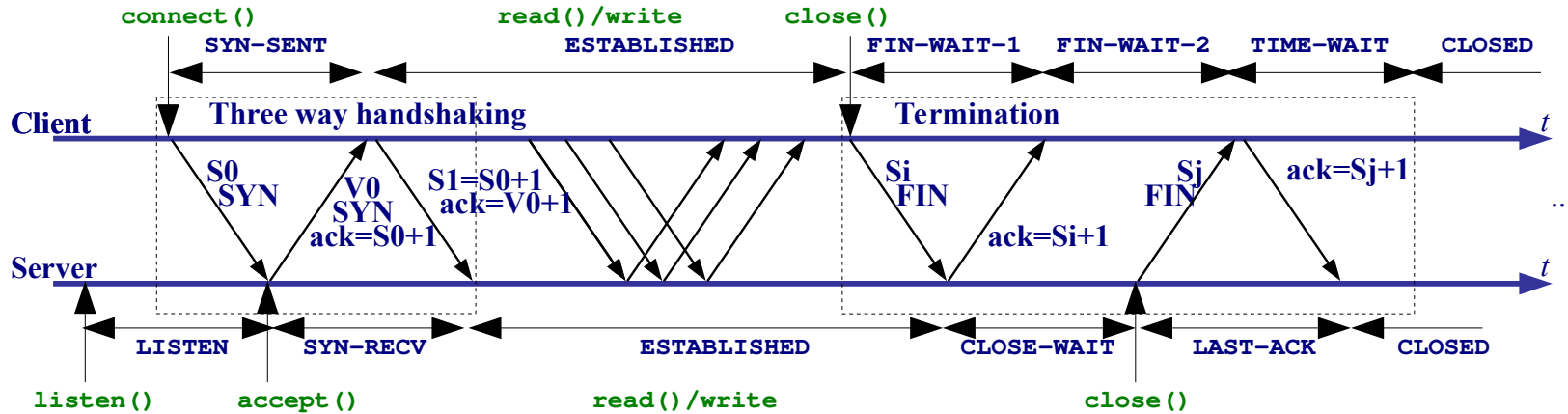



# Unit 4. TCP

## TCP Protocol – netstat dump

- Option -t shows tcp sockets.

```
linux# netstat -nt
Active Internet connections (w/o servers)
Proto Recv-Q Send-Q Local Address           Foreign Address         State
tcp        0     1286 192.168.0.128:29537     199.181.77.52:80      ESTABLISHED
tcp        0      0 192.168.0.128:13690   67.19.9.2:80         TIME_WAIT
tcp        0      1 192.168.0.128:12339   64.154.80.132:80     FIN_WAIT1
tcp        0      1 192.168.0.128:29529   199.181.77.52:80     SYN_SENT
tcp        1      0 192.168.0.128:17722   66.98.194.91:80      CLOSE_WAIT
tcp        0      0 192.168.0.128:14875   210.201.136.36:80    ESTABLISHED
tcp        0      0 192.168.0.128:12804   67.18.114.62:80      ESTABLISHED
tcp        0      1 192.168.0.128:25232   66.150.87.2:80       LAST_ACK
tcp        0      0 192.168.0.128:29820   66.102.9.147:80      ESTABLISHED
tcp        0      0 192.168.0.128:29821   66.102.9.147:80      ESTABLISHED
tcp        1      0 127.0.0.1:25911       127.0.0.1:80         CLOSE_WAIT
tcp        0      0 127.0.0.1:25912       127.0.0.1:80         ESTABLISHED
tcp        0      0 127.0.0.1:80          127.0.0.1:25911     FIN_WAIT2
tcp        0      0 127.0.0.1:80          127.0.0.1:25912     ESTABLISHED
```

man netstat {

    The count of bytes not copied by the user program connected to this socket.

    The count of bytes not acknowledged by the remote host.

The command `lsof` provides similar info.  
 These commands can be conveniently combined with `watch` e.g.:  
`watch -d lsof -n -i @127.0.1.1`

## Unit 4. TCP

### TCP Protocol – Congestion Control (RFC 2581)

- $wnd = \min(awnd, cwnd)$ 
  - The advertised window (awnd) is used for flow control.
  - The congestion window (cwnd) is used for congestion control.
- TCP interprets **losses as congestion**:

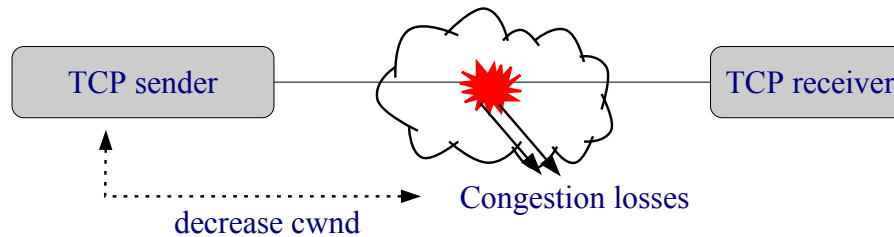

- **Basic Congestion Control Algorithm:**
  - **Slow Start / Congestion Avoidance (SS/CA)**

## Unit 4. TCP

### TCP Protocol – Slow Start / Congestion Avoidance (SS/CA)

- Variables:

- snd\_una**: First non ack segment (head of the TCP transmission queue).
- ssthresh**: Threshold between SS and CA.

**Initialization:**

```
cwnd = MSS ; NOTE: RFC 2581 allows an initial window of 2 segments.
ssthresh = infinity ;
```

Each time an **ack confirming new data** is received:

```
if(cwnd < ssthresh) {
    cwnd += MSS ; /* Slow Start */
} else {
    cwnd += MSS * MSS / cwnd ; /* Congestion Avoidance */
}
```

When there is a **time-out**:

```
Retransmit snd_una ;
ssthresh = max(min(awnd, cwnd) / 2, 2 MSS) ;
cwnd = MSS ;
```

**Time-out Example:**

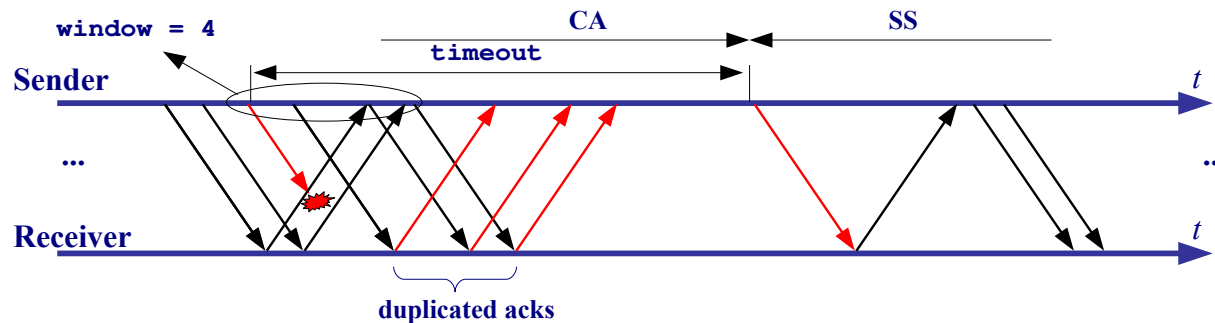

## Unit 4. TCP

### TCP Protocol – Slow Start / Congestion Avoidance (SS/CA)

- During **SS** cwnd is rapidly increased to the “operational point”.
- During **CA** cwnd is slowly increased looking for more available “bandwidth”.

Initialization:

```
cwnd = MSS ;
ssthresh = infinit ;
```

Each time an ack confirming new data is received:

```
if(cwnd < ssthresh) {
    cwnd += MSS ;           /* SS */
} else {
    cwnd += MSS * MSS / cwnd ; /* CA */
}
```

When there is a time-out:

```
Retransmit snd_una ;
ssthresh = max(min(awnd, cwnd) / 2, 2 MSS) ;
cwnd = MSS ;
```

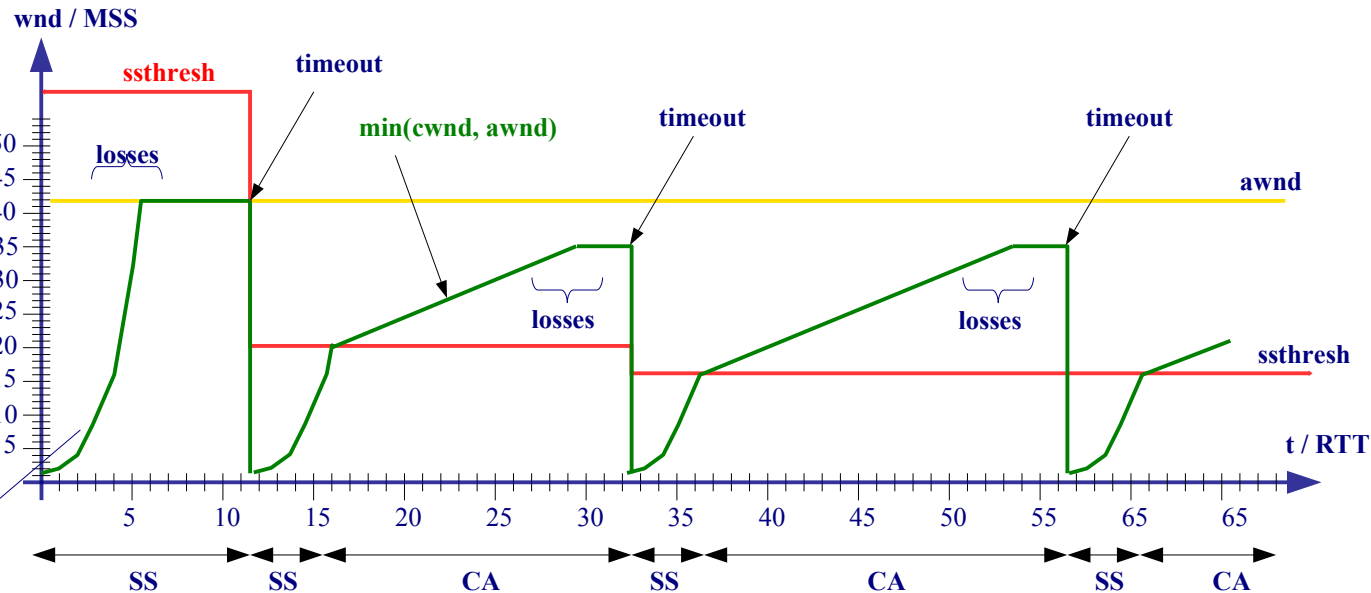

“slow start” is somehow contradictory given the exponential shape :p

## Unit 4. TCP

### TCP Protocol – Evaluation without losses

- Preliminaries:

- TCP sends the entire window,  $W$  (in several segments)
- The segments accumulate in the queues of the interfaces where there are **bottlenecks**
- **Steady state**: the TCP connection started time ago
- In general, we can assume that, on the average, is fulfilled  $v_{ef} = W / RTT$
- If there are no losses,  $W$  will be **awnd**, otherwise  $W$  follows a "saw tooth"

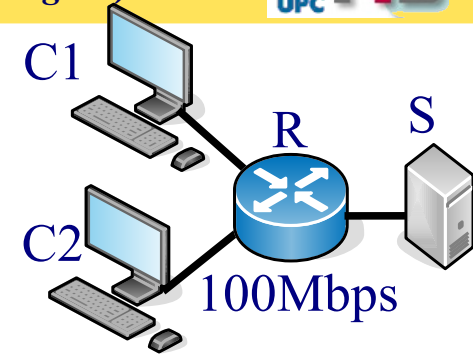

- **Example without losses**: C1 and C2 send to S, each with a TCP connection. Server awnd = 64kB. Router queues  $\geq 128$ kB.

- The **bottleneck** is the link R-S
- For each connection  $v_{ef} = 100/2 = 50$  Mbps
- If the propagation delays in the links are negligible and no losses occur in the **queue of the router** there will be 128 kB (the 2 TCP windows)

- The **RTT** is the time in the queue of the router:
  - $RTT = 128 \text{ kB} / 100 \text{ Mbps} = 10,24 \text{ ms}$
- Check that  $v_{ef} = W / RTT = 64 \text{ kB} / 10,24 \text{ ms} = 50 \text{ Mbps}$

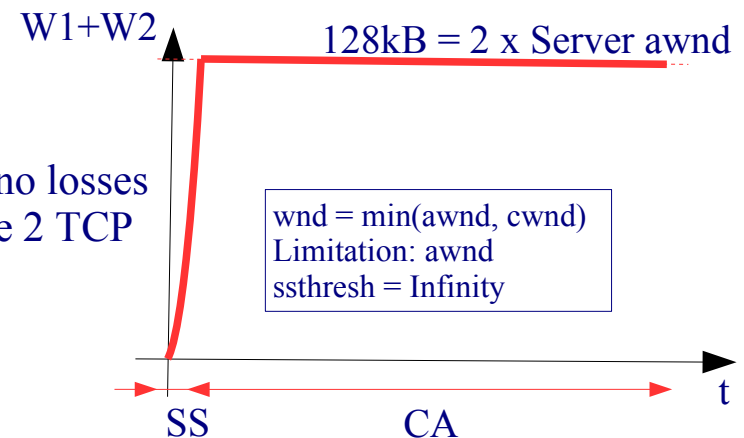

## Unit 4. TCP

### TCP Protocol – Evaluation with losses

- **Example with losses:** C1 and C2 send to S, each with a TCP connection. Server awnd = 64kB. Assume now that the interface **queue of the router** is limited to  $Q = 100 \text{ kB}$

- The **bottleneck** is the link R-S
- For each connection  $v_{ef} = 100/2 = 50 \text{ Mbps}$
- There will be **losses**, because when both TCP windows add to 100kB, there will be no space left in the router queue.
- The figure shows a possible **evolution of the queue** in the router, which stores the window of both connections:  $W1+W2$ . When the queue is full, both connections have losses and reduce the ssth to the half. Therefore, the **average queue size** in the router will be, approximately:

$$(Q/2+Q)/2=3/4Q=75 \text{ kB}$$

- Thus, the **average RTT** will be:

- $\overline{RTT} = 75 \text{ kB} / 100 \text{ Mbps} = 6 \text{ ms}$

- Note that the **average window** of each connection will be:

$$\overline{W1} = \overline{W2} = 75 \text{ kB} / 2 = 37,5 \text{ kB}$$

- Check that  $v_{ef} = \overline{W} / \overline{RTT} = 37,5 \text{ kB} / 6 \text{ ms} = 50 \text{ Mbps}$

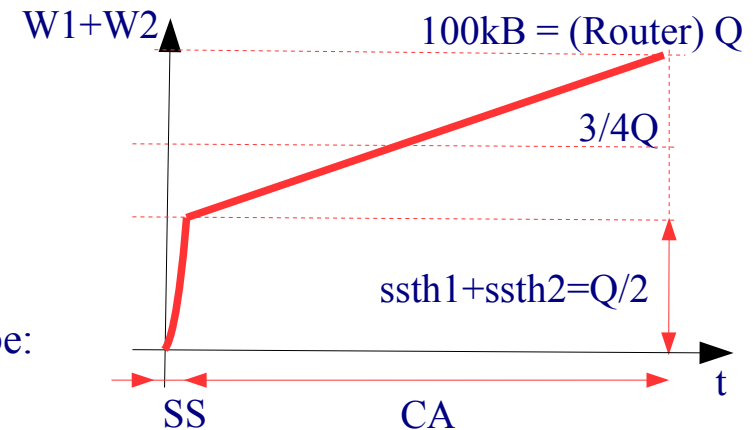
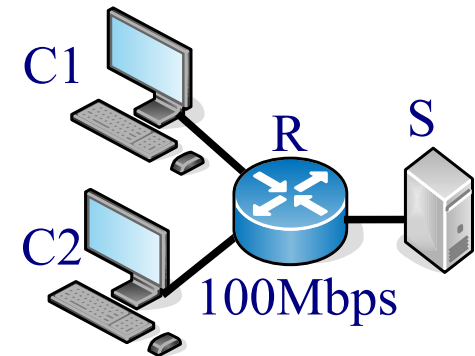

wnd = min(awnd, cwnd)  
Limitation: cwnd  
ssthresh =  $Q/2$

## Unit 4. TCP

### TCP Protocol – Retransmission time-out (RTO)

- Activation:
  - RTO is active whenever there are **pending acks**.
  - When RTO is active, it is continuously decreased, and a ReTx occurs when RTO reaches zero.
  - Each time an **ack confirming new data** arrives:
    - RTO is computed.
    - RTO is restarted if there are pending acks, otherwise, RTO is stopped.
- Computation:
  - The TCP sender measures the **RTT mean** (srtt) and **variance** (rttvar).
  - The retransmission time-out is given by:  **$RTO = srtt + 4 \times rttvar$** .
  - **RTO is duplicated each retransmitted segment** (exponential backoff).
- **RTT** measurements:
  - Using “slow-timer tics” (coarse).
  - Using the TCP timestamp option.

# Unit 4. TCP

## TCP Protocol – Retransmission time-out (RTO)

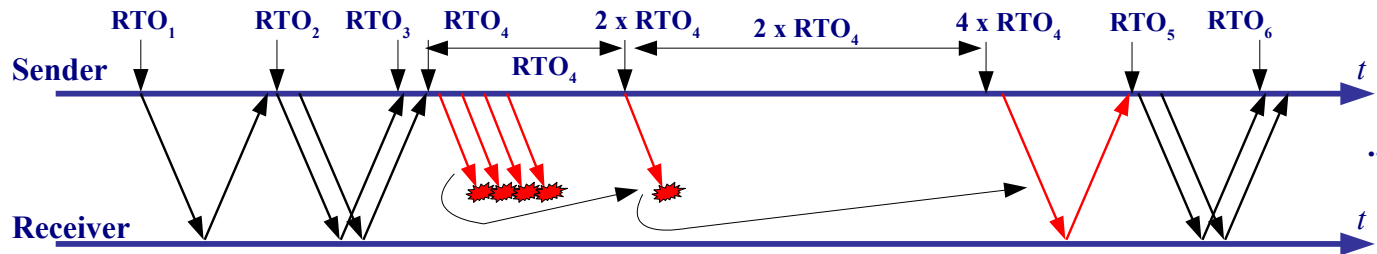

## Unit 4. TCP

### TCP Protocol – Example: TCP echo server

- Code extracted from <https://docs.python.org/3/library/socket.html>
- Run the example in 3 terminals (you can also run it step-by-step in 2 python consoles):
  - 1) `wireshark -n -i any -k -f "host 127.0.1.1"`
  - 2) `python3 serverTCP.py`
  - 3) `python3 clientTCP.py`

Attention!!!

#### serverTCP.py

```
import socket
HOST = '' # Symbolic name meaning all available interfaces
PORT = 50007 # Arbitrary non-privileged port

MAX_DATA = 128*1448 # Must be larger than the data sent by
                    # the client (RST otherwise)
with socket.socket(socket.AF_INET, socket.SOCK_STREAM) as s:
    s.setsockopt(socket.IPPROTO_TCP, socket.TCP_MAXSEG, 1460)
    s.bind((HOST, PORT))
    s.listen(1)
    conn, addr = s.accept()
    with conn:
        print('Connected by', addr)
        while True:
            data = conn.recv(MAX_DATA)
            if not data: break
            conn.sendall(data)
```

#### clientTCP.py

```
# WARNING: GNU/Linux - To make the OS stick to MSS run:
# sudo ethtool -K lo tso off

import socket

HOST = '127.0.1.1' # Server IP
PORT = 50007 # Server port
MSS = 1448 # TCP MSS

#MSG = s.sendall(b'Hello, world')
MSG = 2*MSS*b'a'

with socket.socket(socket.AF_INET, socket.SOCK_STREAM) as s:
    s.setsockopt(socket.IPPROTO_TCP, socket.TCP_MAXSEG, MSS)
    s.connect((HOST, PORT))
    s.sendall(MSG)
    data = s.recv(len(MSG))
```

**generic-receive-offload: off**  
**print('Received', repr(data))**

# Unit 4. TCP

## TCP Protocol – Example: TCP echo server

Time	No.	Source	Destination	Protocol	Length	Info
0.000000000	1	127.0.0.1	127.0.1.1	TCP	76	35964 → 50007 [SYN] Seq=0 Win=65495 Len=0 MSS=65495 SACK_PERM=1 TSval=919802755 TSecr=0 WS=128
Time (format as specified)		127.0.1.1	127.0.0.1	TCP	76	50007 → 35964 [SYN, ACK] Seq=0 Ack=1 Win=65483 Len=0 MSS=65495 SACK_PERM=1 TSval=4252976948 TSecr=919802755 WS=128
0.000029126	3	127.0.0.1	127.0.1.1	TCP	68	35964 → 50007 [ACK] Seq=1 Ack=1 Win=65536 Len=0 TSval=919802755 TSecr=4252976948
0.000060134	4	127.0.0.1	127.0.1.1	TCP	80	35964 → 50007 [PSH, ACK] Seq=1 Ack=1 Win=65536 Len=12 TSval=919802755 TSecr=4252976948
0.000064953	5	127.0.1.1	127.0.0.1	TCP	68	50007 → 35964 [ACK] Seq=1 Ack=13 Win=65536 Len=0 TSval=4252976948 TSecr=919802755
0.000213641	6	127.0.1.1	127.0.0.1	TCP	80	50007 → 35964 [PSH, ACK] Seq=1 Ack=13 Win=65536 Len=12 TSval=4252976948 TSecr=919802755
0.000220747	7	127.0.0.1	127.0.1.1	TCP	68	35964 → 50007 [ACK] Seq=13 Ack=13 Win=65536 Len=0 TSval=919802755 TSecr=4252976948
0.000289663	8	127.0.0.1	127.0.1.1	TCP	68	35964 → 50007 [FIN, ACK] Seq=13 Ack=13 Win=65536 Len=0 TSval=919802755 TSecr=4252976948
0.000358987	9	127.0.1.1	127.0.0.1	TCP	68	50007 → 35964 [FIN, ACK] Seq=13 Ack=14 Win=65536 Len=0 TSval=4252976948 TSecr=919802755
0.000374648	10	127.0.0.1	127.0.1.1	TCP	68	35964 → 50007 [ACK] Seq=14 Ack=14 Win=65536 Len=0 TSval=919802755 TSecr=4252976948
650.667033500	11	127.0.0.1	127.0.1.1	TCP	76	47628 → 50007 [SYN] Seq=0 Win=65495 Len=0 MSS=65495 SACK_PERM=1 TSval=920453422 TSecr=0 WS=128
650.667051418	12	127.0.1.1	127.0.0.1	TCP	76	50007 → 47628 [SYN, ACK] Seq=0 Ack=1 Win=65483 Len=0 MSS=65495 SACK_PERM=1 TSval=4253627615 TSecr=920453422 WS=128
650.667062793	13	127.0.0.1	127.0.1.1	TCP	68	47628 → 50007 [ACK] Seq=1 Ack=1 Win=65536 Len=0 TSval=920453422 TSecr=4253627615
650.667087914	14	127.0.0.1	127.0.1.1	TCP	80	47628 → 50007 [PSH, ACK] Seq=1 Ack=1 Win=65536 Len=12 TSval=920453422 TSecr=4253627615
650.667092691	15	127.0.1.1	127.0.0.1	TCP	68	50007 → 47628 [ACK] Seq=1 Ack=13 Win=65536 Len=0 TSval=4253627615 TSecr=920453422
650.667105953	16	127.0.0.1	127.0.1.1	TCP	68	47628 → 50007 [FIN, ACK] Seq=13 Ack=1 Win=65536 Len=0 TSval=920453422 TSecr=4253627615
650.667268260	17	127.0.1.1	127.0.0.1	TCP	80	50007 → 47628 [PSH, ACK] Seq=1 Ack=14 Win=65536 Len=12 TSval=4253627615 TSecr=920453422
650.667283291	18	127.0.0.1	127.0.1.1	TCP	56	47628 → 50007 [RST] Seq=14 Win=0 Len=0

Lines 1-10: generated with the code of the previous slide

Lines 11-18: generated by removing the lines `'data = s.recv(1024)'` and `'print('Received', repr(data))'` from the client's code of the previous slide